



Kiteboarding
Air Games
GO BIG 

RULEBOOK 2018



Table of Content

1	INTRODUCTION.....	4
2	FUNDAMENTAL RULES.....	4
2.1	Language.....	4
2.2	Rule Intentions.....	4
2.3	Responsibility of Competitors.....	5
2.4	Safety.....	5
2.5	Safety Systems.....	5
3	DEFINITIONS	6
3.1	Abandonment.....	6
3.2	Capsize.....	6
3.3	Clear Astern / Clear Ahead / Overlap.....	6
3.4	Competing.....	6
3.5	Keep Clear	6
3.6	Leeward and Windward	6
3.7	Looping	7
3.8	Mark.....	7
3.9	Overtaking.....	7
3.10	Postponement.....	7
3.11	Representative	7
3.12	Riders Representative	7
3.13	Room	7
3.14	Rule.....	7
3.15	Sports Commission	8
3.16	Tack, Starboard or Port	8
3.17	Tangle	8
3.18	Transition.....	8
3.19	Twin Tip	8
4	EVENT DISCIPLINES AND DIVISIONS.....	9
4.1	Event Disciplines	9
4.2	Divisions.....	9
5	SUITABLE CONDITIONS.....	9
6	ORGANIZERS AND NATIONAL AUTHORITIES.....	10
6.1	Event Organizers, National Authorities and Race Committee.....	10
6.2	Event Officers.....	10
7	ELIGIBILITY AND REGISTRATION OR MEMBERSHIP KWT.....	10
7.1	Eligibility.....	10
7.2	Entry procedure and Registration.....	11
7.3	Entry restrictions.....	12
8	EQUIPMENT.....	13
9	ADVERTISING.....	13
9.1	Requirement to carry advertising.....	13
10	GENERAL ATTITUDE AND RESPONSIBILITY AT EVENTS.....	14
10.1	Attitude.....	14
10.2	Social media.....	14
10.3	Exhibition events.....	15
10.4	Official attendance.....	15

11	DISCIPLINARY CODE OF CONDUCT AND FINES.....	16
11.1	General codes and fines.....	16
11.2	Fines.....	16
12	EVENT SCORING.....	20
12.1	Principles of scoring.....	20
12.2	Ties.....	20
13	ANNUAL RANKING LIST.....	21
13.1	Ranking points.....	21
14	PRIZE MONEY.....	23
14.1	Prize money.....	23
14.2	Prize money distribution.....	23
14.3	Incomplete Events.....	25
14.4	Shared positions.....	26
15	RACE NOTICE.....	26
15.1	Publication and content of the Race Notice.....	26
16	SAILING INSTRUCTIONS AND OFFICIAL NOTICE BOARD.....	27
16.1	Publication and content of the Sailing Instructions.....	27
16.2	Official Notice Board (ONB) and Official Flag Pole (OFP).....	28
16.3	Oral Instructions.....	28
17	PENALTIES AND REDRESS.....	28
17.1	Penalties.....	28
17.2	Redress.....	29
18	ENTRY ALLOCATION AND SEEDING.....	29
18.1	Entry allocation.....	29
18.2	Seeding and Elimination Procedure	30
18.3	Heat distribution	31
19	ELIMINATION LADDERS AND SCORING.....	33
19.1	Elimination ladders.....	33
19.2	Heat Schedule.....	41
19.3	4 Riders Heat.....	41
19.4	Male Heats Double Elimination.....	42
19.5	Discipline Scoring.....	42
20	COMPETITION FORMAT AND PROCEDURE.....	52
20.1	Competition Format.....	52
20.2	Signals and heat duration.....	54
20.3	Postponing and abandoning a heat.....	54
21	RIGHT OF WAY RULES.....	55
21.1	General Right of way rules.....	55
22	JUDGING.....	57
22.1	Judging Procedure.....	58
22.2	Scoring	59
22.4	Judging Criterias and scoring categories:	61
22.5	Other judging aspects.....	62
23	INTELLECTUAL PROPERTY RIGHTS.....	62

1 INTRODUCTION

GKA Kiteboarding World Tour (KWT) Rulebook is published by Kiteboarding World Tour (KWT) Sport Committee in January 2018. This Rulebook will be revised and published every year by the Kiteboarding World Tour (KWT) Sport Committee.

Kiteboarding World Tour (KWT) competitions are sanctioned and approved by the Global Kitesports Association e.V. (GKA).

All Kiteboarding World Tour (KWT) competitions shall be managed under the Kiteboarding World Tour (KWT) Event Organizers Manual and the Kiteboarding World Tour (KWT) Rulebook.

2 FUNDAMENTAL RULES

2.1 *Language*

- 2.1.1 English is the official language of the Kiteboarding World Tour, which will henceforth be referred to as KWT.

2.2 *Rule Intentions*

- 2.2.1 The event rules are designed to allow the best competitor to win because of their high level of skill, good use of equipment and good fortune. The rules are not designed to allow a winner to prevail because of certain procedures or raising arguments over legalities.

All disputes surrounding rules should be carried out with regard to this principle.

2.3 Responsibility of Competitors

- 2.3.1 Each competitor is responsible to decide whether or not to start or to continue the competition and to provide for their safety.

2.4 Safety

- 2.4.1 The most important aspects of competition are safety and fair play. Unsafe competitors will be warned, fined or disqualified.
- 2.4.2 Sailing in a manner that can be considered to be dangerous or a threat to the safety of other competitors will not be tolerated. All disputes under the rules shall be conducted on this principle.
- 2.4.3 When in a position to do so, each competitor must render every possible assistance to a competitor in danger and assist organizers with any rescue information in the event of a rescue being needed.

2.5 Safety Systems

- 2.5.1 Safety leashes that ensure the kite remains secured to the harness once the quick release safety system has been deployed are compulsory for all competitors. Each competitor must use a reliable quick release safety system. Competitors will be disqualified from the race or event if they ride without a safety leash.
- 2.5.2 In the event of a dangerous occurrence, chicken loops that safely release all power from the kite must be installed on all competitors' kite bars.
- 2.5.3 Unless included in the Race Notice or the specific event instructions, helmets and personal flotation devices are optional. If a Race Notice of a specific event does require personal buoyancy, then every rider / competitor must wear a personal flotation device that conforms to the minimum ISO 12402-5 (Level 50) standard requirement. (A Race Notice may however allow for alternative or additional standards).
- 2.5.4 Kite launching and landing areas for competitors' equipment will be defined by the event organizer and that zone must be respected. Spectator access will be restricted and any media representatives will need to be authorized by the Contest Director to access this area - and they will do so at their own risk.

3 DEFINITIONS

3.1 Abandonment

3.1.1 An abandoned heat is one which the Race Committee declares void at any time after the starting signal, and which may be re-sailed at its discretion.

3.2 Capsize

3.2.1 A competitor is capsized if

- (i) their kite is in the water,
- (ii) their lines are tangled with another competitor's lines, or
- (iii) the competitor has, clearly by accident and for a significant period of time,
 - (a) fallen into the water or
 - (b) become disconnected from the hull.

3.3 Clear Astern / Clear Ahead / Overlap

3.3.1 A board is clear astern of another when its hull and rig are abaft an imaginary line projected abeam from the aftermost point of the other's hull and rig. The other board is clear ahead. The boards overlap when neither is clear astern.

3.4 Competing

3.4.1 A board is competing from its starting signal until the finishing signal or until the heat has been postponed or abandoned or until the competitor has finished their jump.

3.5 Keep Clear

3.5.1 A competitor keeps clear of a right- of- way competitor

- (i) if the right- of- way competitor can sail her course with no need to take avoiding action and,
- (ii) when the competitors are overlapped, if the right- of- way competitor can also, without immediately making contact, change course in both directions or move their kite in any direction.

3.6 Leeward and Windward

3.6.1 A competitor's leeward side is the side that is or, when they are head to wind, was away from the wind. However, when sailing by the lee or directly downwind, their leeward side is the side on which their kite lies. The other side is their windward side. When two

competitors on the same tack overlap, the one whose hull is on the leeward side of the other's hull is the leeward competitor. The other is the windward competitor.

3.7 Looping

3.7.1 A kite is looping when it is being flown in a single loop or in a pattern of repeated loops, clockwise, counter clockwise or alternating between the two.

3.8 Mark

3.8.1 A mark is any object specified in the Sailing Instructions which delimits the competition area.

3.9 Overtaking

3.9.1 A board is overtaking from the moment it gains an overlap from clear astern until the moment it achieves a position clear ahead of the overtaken board.

3.10 Postponement

3.10.1 A postponed heat is one which is not started at its scheduled time and which may be sailed at any time the Race Committee may decide.

3.11 Representative

3.11.1 Any individual with a power authorized under this Rulebook and designated on the Notice of Race or Sailing Instructions.

3.12 Riders Representative

3.12.1 A nominated individual by the competitors. This representative is to be nominated amicably between the competitors present or available at the Event. If this decision cannot be made, the highest-ranking competitor per discipline will make a unilateral decision on the Representative provided the competitor accepts the decision.

3.13 Room

3.13.1 The space a kiteboard needs in the existing conditions, including space to comply with her obligations under right- of- way rules, while maneuvering promptly in a seamanlike way.

3.14 Rule

- 3.14.1 The rules in this Rulebook, including the Definitions, Race Signals, Introduction or announcements posted in the Official Notice Board together with any update as published in the GKA Website;
- 3.14.2 the rulebook;
- 3.14.3 the Notice of Race;
- 3.14.4 the Sailing Instructions; and
- 3.14.5 any other documents that govern the event.

3.15 Sports Commission

- 3.15.1 An appointed commission by the GKA Board members formed by the Sports Director and two GKA Management members who decide on the most relevant KWT competition aspects.

3.16 Tack, Starboard or Port

- 3.16.1 A competitor is on a tack, starboard or port, corresponding to the competitor's hand that would be forward if the competitor were in normal riding position (riding heel side with both hands on the control bar and arms not crossed). A competitor is on starboard tack when the competitor's right hand would be forward and is on the port tack when the competitor's left hand would be forward.

3.17 Tangle

- 3.17.1 Two or more competitors shall be considered as tangled when the lines of one kite are wrapped around the lines of another kite.
- 3.17.2 It is not considered a tangle when kites bump into each other nor when the kite tip catches the lines of another kite without wrapping around. Even if both kites capsize (kites in the water) as a result of the contact, this is not a tangle (unless tangled as a result of above action).
- 3.17.3 If both kites remain in the air and are quickly separated, this is not considered a tangle even if there is a slight wrap- around.

3.18 Transition

- 3.18.1 A board in transition is one that is changing direction either tacking or gybing or performing a manoeuvre specifically designed to change tacks. A transition starts when the kiteboard changes course and finishes when is sailing on the new tack.

3.19 Twin Tip

3.19.1 The board used by a competitor to compete.

4 EVENT DISCIPLINES AND DIVISIONS

4.1 *Event Disciplines*

4.1.1 There will be just one Official Discipline in a KWT event.

4.1.2 Other Special or Show Disciplines may be scheduled in an event.

4.2 *Divisions*

4.2.1 A KWT event may include one or both from the following divisions:

- Pro Men: any age (Minimum 14 years old).
- Pro Women: any age. (Minimum 14 years old).

4.2.2 Divisions may be created or merged if there are less than six (6) competitors registered per division.

4.2.3 Competitors can only compete in one division per competition.

4.2.4 All scheduled divisions at the events shall be announced in the Race Notice.

5 SUITABLE CONDITIONS

5.1 The competition must take place in suitable conditions. This decision shall be made by Race Director, KWT Representative and / or the Head Judge.

When assessing if the conditions are suitable for competition in all disciplines, the event organizing team will take into account the wind speed, wind direction, temperature, incoming and current weather, wave size and ocean currents.

5.2 Shelter on the beach and sensible provisions such as hot food and drinks must be provided by the event organizer if the air temperature drops below 10° Celsius during the competition.

5.3 Competition will not run if the water temperature is not at least 8° Celsius or above.

5.4 The ruling on conditions is final. Protests surrounding the suitability of the conditions will not be heard / taken into account.

6 ORGANIZERS AND NATIONAL AUTHORITIES

6.1 Event Organizers, National Authorities and Race Committee

6.1.1 KWT recognized and sanctioned events will be run and organized by an individual or group that is recognized by the KWT. From here on they shall be recognized and referred to by the term 'Event Organizer'. The Manual and KWT rulebook will form the basis and protocol for judging and organization of all KWT competition.

6.1.2 **National Authorities**

The KWT may recognize all legally constituted National Kiteboarding Bodies.

6.1.3 **Race Committee**

Subject to such direction as the GKA and KWT may exercise, all competitions shall be conducted and judged by the Race Committee in conformity with the terms and conditions published in the Race Notice. The term "Race Committee", whenever it is used, shall include any person or committee responsible for carrying out any of the designated duties or functions of the Race Committee. The head of the Race Committee should be the Contest Director, Head Judge or any other person named in this document as the head of the Race Committee

6.2 Event Officers

6.2.1 The KWT events shall have the following:

- (i) A Contest Director.
- (ii) A Head Judge.
- (iii) At least 5 Judges.
- (iv) A KWT Representative

6.2.2 If the Contest Director and Head Judge is the same person, then one of the other Judges could also act as the Head Judge if the need arises.

6.2.3 Under special circumstances KWT can also run by 4 judges and one Head Judge.

7 ELIGIBILITY AND REGISTRATION OR MEMBERSHIP KWT

7.1 Eligibility

7.1.1 A competitor is eligible for any KWT event if he meets the following conditions:

- (i) He is a member of his Official National Kiteboarding Federation or Association.
A valid membership card or certificate, or other satisfactory evidence of identity and membership may be requested.
- (ii) He has a personal medical insurance with worldwide coverage.
A valid membership card or certificate, or other satisfactory evidence of worldwide medical coverage may be requested.
- (iii) The competitor can not hold responsible the KWT, the GKA or the event-organizer for any claims for damages as a consequence of the competitor not having sufficient personal medical insurance.
- (iv) The competitor can not hold responsible the KWT, the GKA or the event-organizer for any legal liabilities and/or any claims for damages by third parties caused by the competitor.
- (v) He complies with World Sailing Federation Regulation, Eligibility Code.

7.1.2 The KWT Officer will look after all entries. Although allocated wildcard positions can be awarded by the Event Organizer or the National Association.

7.1.3 The Rulebook specifies the maximum number of 64 competitors registered for a KWT event per discipline, including the wildcards, though these may be modified in the Race Notice

7.1.4 The Race Notice will give the specifications and information regarding registration.

7.1.5 In order to enter the event, Parental consent / authorization must be received for all competitors who are under the age of 18 years old at the registration date.

7.1.6. The right to refuse the registration of any individual whose participation is not in the best interest of the event or the sport is reserved by the KWT.

7.2 Entry procedure and Registration

7.2.1 All competitors planning to enter a KWT event shall pre-register online on the GKA website or by other means to be specified by the KWT Sports Commission, no later than the published closing date for entries for that specific event.
Ultimately it is the competitors' responsibility to pre-register or to apply for an entry for an event and to ensure that the application has been received timely and correctly.

- 7.2.2 According to rule 10.2, fines and/or having their next events applications cancelled may be handed out to a pre-registered and / or qualified competitor who, without advanced notice fails to show up at an event.
- 7.2.3. Complete and signed entry forms for event registration must be signed and complete by the time stated in the Race Notice. Exceptions can only be granted by the KWT Representative.
- 7.2.4 If a competitor is unable to complete registration at the published time and place in the Race Notice for reasons beyond their control, then the competitor should contact the KWT Representative with details of their delay, and must gain consent for their registration period to be extended. Evidence must be supplied to support reasons showing that the circumstances we/are out of the competitor's control. Failure to comply with the above will prohibit a competitor from entering the event.

7.3 Entry restrictions

- 7.3.1 Inscription-fee payments must be made no later than the end of the inscription-time at the respective event.
- 7.3.2 In the case that the full amount of the inscription fee is not paid by the end of the announced inscription-time, the rider will not be allowed to compete.
- 7.3.3 Payments can be made in cash at the inscription at the respective event.
- 7.3.4 Cash-payments will only be accepted in Euros or US\$ currency.
- 7.3.5 Inscription fee payments can also be made by bank-transaction.
- 7.3.6 Inscription fee payments via bank-transaction have to be credited to the GKA bank-account 7 days prior to the first day of the event.
- 7.3.7 Bank transaction-costs are paid by the rider.
- 7.3.8 Inscription fee payments made via bank-transaction must show:
 - (i) Full rider's name
 - (ii) Name of the event the inscription fee is being paid for:
- 7.3.9 In the case that the inscription fee payments is not made by bank-transaction but in cash an amount of 20,- Euro processing fee will be added to the regular inscription-fee.

8 EQUIPMENT

- 8.1 There are no restrictions on equipment.
- 8.2 To be eligible for competition, boards must work and be powered independently to the kite system.
- 8.3 Only the power of wind in the kite or water on the board's hull can propel the competitor. Other than that the competitor must remain unassisted. The kiteboard should not make significant progress by swimming, paddling or walking with it.
- 8.4 If the Contest Director deems that certain equipment could cause injury to any riders / competitors / public, then it must be prohibited.
- 8.5 Every competitor must take responsibility with regard to having their equipment checked by the Contest Director. Failure to obey instructions may lead to a penalty / fine under rule 11.2.
- 8.7 In the interests of safety and maintaining high standards of fair play, the KWT reserves the right to impose further restrictions on equipment. Prohibition will not be made without being announced in the Race Notice.

9 ADVERTISING

9.1 *Requirement to carry advertising*

- 9.1.1 For the entire event, including registration day, whether competing, riding as part of an exhibition or other fun event, warming up in the designated area, being interviewed by event media or official press teams, or at any presentations or when on any podiums, all riders, if required by the Race Notice or Contest Director, shall:
- (i) Wear a standard KWT specification, Event or Tour advertising vest over all other clothing, including harness and life jacket and / or
 - (ii) Carry Event / Tour advertising stickers in the correct position on the board, kite or lines.
- 9.1.2 Instructions from the Race Notice, Sailing Instructions, the Contest Director or KWT Representative must be followed by Competitors in regard to the proper placement of advertising.
- 9.1.3 Advertising that is provided must all be in good taste and well represented as judged by the KWT Representative or Contest

Director. Any branding not deemed to be in good taste by the Contest Director or KWT Representative must be replaced with immediate effect.

- 9.1.4 Each competitor must take sole responsibility to correctly wear their competition vest at all times during the event.
- 9.1.5 Competitors shall make every effort to guarantee that event and sponsor branding is appropriately respected and neatly arranged on their kite, board, or even their lines. If advertising / branding stickers are lost during competition because of adhesion problems, then a rider will not be held responsible for that.
- 9.1.6 Competitors can be subject to a fine if they fail to comply with any of the above rules according to rule 11.2 fine schedules. Future event entry application may also be cancelled as a result.

10 GENERAL ATTITUDE AND RESPONSIBILITY AT EVENTS

10.1 *Attitude*

- 10.1.1 All members must, by their actions and general attitude, during all events and at all times while within the boundaries of the recognized KWT site or sanctioned events, promote the image of the sport, the sponsors of the event, the KWT and themselves in a professional manner.

Any failure to do so immediately prior to, during and immediately after a KWT event may result in appropriate fines being levied by the KWT. More severe cases of bringing the sport into disrepute may result in the suspension or expulsion of a competitor from the KWT after due consideration by the KWT Sports Commission.

10.2 *Social media*

- 10.2.1 Any post on social media channels made by any member, competitor or Event Official will be considered a public statement. A post considered abusive or detrimental to the best interests of the KWT and the sport in general, or that could be considered to bring the KWT or the sport into disrepute shall be considered as an unsportsmanlike conduct and may be penalized under rule 11.2 fine schedules.
- 10.2.2 Any post from a competitor on social media about a sanction imposed under this Rulebook shall be done with the consent of the KWT Representative.

10.3 Exhibition events

- 10.3.1 An exhibition event does not count towards the official result. If instructed by the Contest Director, all registered competitors must compete in exhibition events or races. The Contest Director must first obtain the KWT Representative's permission to hold exhibition races in which the competitors are required to participate.
- 10.3.2 Failure by a competitor to participate without the KWT Representative's prior permission may lead to a penalty under rule 11.2 fine schedules. Future event entry applications may also be cancelled.

10.4 Official attendance

- 10.4.1 **Mandatory competitor's meeting**
A mandatory meeting for all competitors at least half-an-hour before the start of the first heat / race will take place on the first day of official competition. All competitors will receive an announcement as to the official time and location for the meeting at registration.
- 10.4.2 **Media conference and interviews**
All competitors may be required to attend a post heat / race media conference immediately after the end of the heat / race or at any reasonably possible time, taking into kindness the commitments of competition, whether he / she is the winner or the loser. Competitors must wear the event sponsors' advertising vest or a suitable substitute supplied by the Event Organizer or KWT Representative during this conference as required.
- 10.4.3 **Official ceremonies and events**
It is mandatory for all competitors to ensure their punctual attendance at all scheduled official events or ceremonies announced in the Race Notice or Sailing Instructions.
- 10.4.4 **Presence on site**
All riders / competitors are required to stay within the event site boundaries for the entire duration of the event, as published in the Race Notice. Permission in writing must be obtained from the KWT Representative by any rider / competitor wishing to be made exempt from this rule for a particular event.
- 10.4.5 If any competitor fails to comply with any of the above rules they may be penalized under rule 11.2 fine schedules. Future events entry applications may also be cancelled / dismissed.

11 DISCIPLINARY CODE OF CONDUCT AND FINES

11.1 General codes and fines

- 11.1.1 The rules set forth under this section apply to the conduct of each competitor, caddies, coaches, Event officials, KWT staff or competitors' family relatives while within the event site boundaries, except where the specific offenses described therein are considered to bring the sport into disrepute or are directed towards an Event Organizer, sponsor, the KWT or KWT staff.
- 11.1.2 Fines that are applied for breaking this code are payable to the KWT. Any applied fines must be paid before any competitor will be allowed to compete in any further event, race or heat recognized or sanctioned by the KWT.
- 11.1.3 The KWT Representative, Contest Director or Head Judge may discipline and fine competitors. In all cases the Contest Director and / or Head Judge shall consult with the KWT Representative before imposing any fines or penalties under the code of conduct.
- 11.1.4 The Event committee will consider the seriousness of the offense, the current ranking of the competitor and if the rule violation is a repetition when imposing a fine or penalty.
- 11.1.5 Fines may be imposed for each individual rule violation. If different rules have been broken / violated during a single incident, each individual violation of the rules may be penalized accordingly.
- 11.1.6 The KWT will notify any competitors in writing of fines levied against them. Any competitor wishing to appeal against a fine may submit a written appeal to the KWT. This appeal will be considered by a committee consisting of the Head Judge, a KWT Representative and a Management Board representative. Where it is not possible for an appeal to be heard by this committee i.e. after an event has finished, then the appeal may be heard by the KWT Sports Commission.

11.2 Fines.

- 11.2.1 Failure to obey written or verbal instruction
If a competitor or relative fails to follow clear written or verbal instructions at an event, they may be subject to a fine of not more than \$500.
- 11.2.2 Kiting in the course / competition area when not competing

Breaches of conduct under this rule will incur a fine of no more than \$300 per violation and / or a warning or disqualification from the series or event.

- 11.2.3 Failure to return the colored advertising vest after the heat
Any competitor failing to return their colored lycra vest after their heat when returning to the beach will incur a fine of no more than \$50 per violation.
- 11.2.4 Failure to attend an event that a competitor has entered
Any pre- registered and / or qualified competitor who fails to attend the event without personal advance notice and / or has an adequate excuse (as determined by the KWT Sports Commission) will incur a fine of no more than \$1,000 and / or may have their next event entry applications cancelled / dismissed. If a competitor / rider fails to attend events on multiple occasions, the loss of seeding rights shall be increased by one event for each no- show. A competitor who sealed the World Champion title before the end of the season and then fails to attend all remaining events of the current season will incur a fine of no more than \$5,000 per missed event.
- 11.2.5 Failure to compete
Any competitor failing to show at their heat or race before the end of the heat without advance notice and with it being due to any extenuating circumstances, including injury, will incur a fine of no more than \$200 per violation.
- 11.2.6 Littering
Members found to be littering or causing any other environmental damage within the boundaries of the event site will incur a fine of no more than \$200 per violation.
- 11.2.7 First day competitor's meeting
Any rider / competitor failing to attend the first day competitor's mandatory meeting as prescribed in Rule 10.4.1 will incur a fine of no more than \$200.
- 11.2.8 Media conference
Any rider / competitor failing to attend a media conference as prescribed in Rule 10.4.2 will incur a fine of no more than \$500.
- 11.2.9 Official ceremonies or events
Any rider / competitor failing to attend an Official ceremony or event as prescribed in Rule 10.4.3 will incur a fine of no more than \$250.

Any competitor finishing in the top 3 positions who fails to attend the awards ceremony on time - without being justified by a force of major circumstance - will incur a fine equal to their earned prize money for the event.

11.2.10 Presence on site

Any competitor failing to remain present on site as prescribed in Rule 10.4.4 will incur a fine of no more than \$300 and / or a warning or disqualification from the series or event.

11.2.11 Advertising

All riders / competitors are required to abide by the advertising rules as laid out in Rule 8.1. Breaching the rules of the various categories of this section will incur a fine of no more than \$300 for each violation and / or warning or disqualification from the series or event.

11.2.12 Audible obscenities

Any rider / competitor using an audible obscenity in any language will incur a fine of no more than \$500 for each violation. For the verification of this rule, audible obscenities are defined as words commonly known and understood to be profane and uttered clearly and loudly enough to be heard by any officials in the proximity.

11.2.13 Visible obscenities

Any rider / competitor making an obscene gesture of any kind will incur a fine of up to \$500 for each violation and / or warning or disqualification from the series or event. For the verification of this rule, a visible obscenity is defined as the making of signs or gestures by a competitor using his hands, body, or kiting equipment that is commonly understood to have an obscene meaning or message.

11.2.14 Verbal abuse

Any rider / competitor heard to be verbally abusive towards an official, opponent, spectator, member of the media or any other person will incur a fine of no more than \$500 for each violation and / or warning or disqualification from the series or event. For the verification of this rule, verbal abuse is defined as a statement directed at an official, opponent, spectator, member of the media or any other person that implies dishonesty, or is derogatory, insulting or otherwise abusive.

11.2.15 Abuse of event equipment

Any rider / competitor abusing or damaging event equipment, violently or dangerously or with anger, will incur a fine of no more than \$300 plus the costs of repairing or replacing any damaged equipment and / or warning or disqualification from the series, event or elimination.

11.2.16 Physical abuse

Any rider / competitor found to have been physically abusive to an official, opponent, spectator, member of the media or any other person will incur a fine of no more than \$500 for each violation, and / or disqualification from the series or event. For the verification of this rule, physical abuse is the unauthorized touching of an official, opponent, spectator, member of the media or any other person.

11.2.17 Unsportsmanlike conduct

Any rider / competitor failing to conduct themselves in a sportsmanlike manner at all times, and / or to give due regard to the authority of officials and the rights of opponents, spectators, members of the media or other persons will incur a fine of no more than \$5,000 for each violation and / or disqualification from the series or event and / or may have their next event entry applications cancelled / dismissed. For the verification of this rule, unsportsmanlike conduct is defined as any misconduct that is clearly abusive or detrimental to the sport, but does not fall within the prohibition of any specific on site offense contained in these rules. In addition, unsportsmanlike conduct shall include, but not be limited to, the use of illegal drugs, gambling, bribery, sexual harassment or abuse, giving, making issuing, authorizing or endorsing any public statement, having, or designed to have, an effect that is prejudicial or detrimental to the best interests of the KWT, the event or the kiteboarding sport in general.

If the Head Judge believes that a competitor is abusing or misusing the protest system, then he / she may propose that a fine be levied in the category of unsportsmanlike conduct.

11.2.18 Coaches, team managers and family relatives

Riders / Competitors take responsibility for the presence of their coaches, managers, representatives, family relatives and any ancillary staff. The violation of any KWT Code of Conduct rules by any of these individuals will result in the appropriate penalty being applied to the competitor.

11.2.19 Future disciplinary action

When the KWT Representative, Race Director or Head Judge excludes a competitor from further participation in an event, or takes further disciplinary action against the competitor after a gross breach of good manners or unsportsmanlike conduct, their action shall be reported to the Management Board, who may reconsider the matter after further investigation and impose further penalties, including the recovery of costs for any damage caused to property and equipment.

11.2.20 Hotel Accommodation

The good name of KWT and the competitive preparation of competitors should not be compromised by competitors causing damage, inconvenience to other guests or boorish, rowdy behaviour in official hotels or other accommodation. Such behaviour may result in the KWT disallowing a competitor from residing in official hotel accommodation and may result in further action under the Code of Conduct.

Competitors must officially check out of the hotel when involved in a Championship and must pay their room bill (if applicable) and their own hotel extras (e.g. phone, drinks, food). They will be liable for a fine up to \$500 failing to settle a room account and for a fine up to \$250 if they should leave the hotel without paying all they hotel extras.x

12 EVENT SCORING

12.1 *Principles of scoring*

12.1.1 All eliminations are scored uniformly.

12.1.2 The positions in the individual disciplines shall be established by means of the total score earned over the valid races or elimination series held in each discipline

12.2 *Ties*

12.2.1 If there is a tie in total points, the tie shall be broken as follows:

- (i) The competitor(s) with the best elimination score in their last round will win.
- (ii) If a tie remains between two or more competitors, each competitor's elimination scores in their last round shall be listed in order of best to worst individual scores, even if some of them are excluded scores, and at the first point where there is a difference the tie shall be broken in favor of the competitor with the best individual score.
- (iii) If a tie still remains between two or more competitors, they shall be ranked in order of their scores in the previous elimination. This process shall continue until all ties are broken. These scores shall be used even if some of them are excluded scores.

13 ANNUAL RANKING LIST

13.1 *Ranking points*

13.1.1 Competitors will be awarded points according to the table below and their finishing position after a valid event result.

Position	Points	Position	Points
1	2100	33	1044
2	2067	34	1011
3	2034	35	978
4	2001	36	945
5	1968	37	912
6	1935	38	879
7	1902	39	846
8	1869	40	813
9	1836	41	780
10	1803	42	747
11	1770	43	714
12	1737	44	681
13	1704	45	648
14	1671	46	615
15	1638	47	582
16	1605	48	549
17	1572	49	516
18	1539	50	483
19	1506	51	450
20	1473	52	417
21	1440	53	384
22	1407	54	351
23	1374	55	318
24	1341	56	285
25	1308	57	252
26	1275	58	219
27	1242	59	186
28	1209	60	153
29	1176	61	120
30	1143	62	87
31	1110	63	54
32	1077	64	21

13.1.2 The minimum number of races or elimination series per discipline and event for scoring in the KWT annual ranking list of the

respective discipline(s) is one elimination as specified in the relevant subsections of this Rulebook

13.1.3 Incomplete elimination series

For any valid event result - and when the elimination series is incomplete - points will be awarded as follows:

(i) The losers of any round within an elimination series that has been completed shall have the points awarded as per their finishing position according to rule 13.1.1 table, even if competitors are tied.

(ii) For any incomplete round within an elimination series, the points for the occupied position and the following unoccupied positions (equal in number to the competitor's standing on the single position) shall be added together, then divided by the number of the competitors in the group.

13.1.4 The KWT annual ranking for the year will be determined by the combined total of the year's event points after discards. The number of discards shall be in accordance with the table below:

Number of events	Number of events discarded
1 – 4	0
5 – 6	1
7 – 9	2
More than 10	3

13.1.5 The competitor with the highest total score at the end of the year is the KWT Champion.

In 2018 the Tour Champion will be called GKA Kiteboarding World Champion.

13.1.6 Ties in annual ranking lists

When there is a tie in total points of a KWT annual ranking list, the tie shall be broken as follows:

(i) In favor of the competitor who has beaten the other in more events in the relevant discipline excluding all discarded events results.

(ii) If a tie remains between two or more competitors, each competitor's event discipline results shall be listed in order of best to worst, and at the first point(s) where there is a difference the tie shall be broken in favor of the competitor(s) with the best result(s) excluding all discarded events results.

- (iii) If a tie still remains between two or more competitors, they shall be ranked in order of their results in the last event. Any remaining ties shall be broken by using the tied competitors' results in the next- to- last event results and so on until all ties are broken. These results shall be used even if some of them are excluded results.

14 PRIZE MONEY

14.1 *Prize money*

- 14.1.1 Event Organizers and KWT contracts will take precedence when it comes to prize money levels as set by the KWT Management Board and the GKA.
- 14.1.2 The total prize money amount available from the event shall be announced in the Race Notice or entry form.
- 14.1.3 Any competitor who, in the opinion of the Contest Director, causes any unnecessary delay in the smooth running of an event (e.g. not attending the prize giving ceremony on time), or violates any part of the KWT Code of Conduct, may be excluded from this prize split. The Contest Director's decision may not be appealed, although they may be required to give their reasons for the decision in writing.
- 14.1.4 Any rider is responsible by himself or herself for paying the applicable taxes for the prize money received. The rider keeps the KWT, the GKA, the event-organizer and any third party free from the riders' personal tax liabilities. The KWT, the GKA and the event-organizer have the right to inform the tax-authorities about the name of the rider and the amount of prize money received by him or her, if required by the tax-authorities.

14.2 *Prize money distribution*

- 14.2.1 Event Organizers and KWT contracts will take precedence when it comes to prize money levels as set by the KWT Management Board.
- 14.2.2 The total prize money amount at the event for each discipline and division shall be announced in the Race Notice or entry form.
- 14.2.3 The full amount of the advertised prize money shall be payable when a valid result stands as per the rules in the relevant subsections of this Rulebook.

14.2.4 The KWT, the GKA and/or the event-organizer have got the right to subtract the competitors' individual withhold-tax from the prize-money to be paid out. The KWT, the GKA and/or the event-organizer have got the right to pay the individual withhold-tax on behalf of the competitor to the national tax-authorities of the country in which the event takes place. The KWT, the GKA and/or the event-organizer shall give all necessary information and documents of the tax-payment made to the competitor for his personal disposal.

14.2.5 The prize money distribution for a valid and completed KWT event will be done according to the following table:

Single & Dingle:

MALE	
Position	Percentage
1	30,00%
2	22,50%
3	15,00%
4	8,75%
5	5,94%
5	5,94%
5	5,94%
5	5,94%
Total	80%

FEMALE	
Position	Percentage
1	40,00%
2	30,00%
3	20,00%
4	10,00%
Total	20%

Double:

MALE	
Position	Percentage
1	30,00%
2	22,50%
3	15,00%
4	8,75%

FEMALE	
Position	Percentage
1	40,00%
2	30,00%
3	20,00%
4	10,00%

5	7,50%
6	6,25%
7	5,00%
7	5,00%
Total	80%

Total	20%

14.2.6 Women's prize division will be a minimum of 20% with 6 participants and will increase depending on the final number of women in proportion to the number of men competing.

Different scenarios:

	Participants	Percentage
Men	32	80%
Woman	6	20%
Total	38	

	Participants	Percentage
Men	32	70%
Woman	16	30%
Total	48	

14.2.7 If the women's division doesn't take place, the full amount allocated as prize money will be added to the men's division.

14.2.8 Any competitor who, in the opinion of the Contest Director, causes any unnecessary delay in the smooth running of an event (e.g. not attending the prize giving ceremony on time) or a breach of the KWT Code of Conduct may be excluded from this prize split. The Contest Director's decision may not be appealed, although he may be required to give his reasons for his decision in writing.

14.3 Incomplete Events

14.3.1 An event is considered incomplete when there is no official result and no points are awarded as specified in the relevant subsections of this Rulebook.

- (i) The prize money for any incomplete event is divided into two parts. 50% will be returned to the Event Organizer and 50% will

be allocated to all officially registered riders / competitors in the relevant event.

(ii) The 50% allocated to the registered rider/competitors will be distributed as follows:

a) If no single column within an elimination series has been completed, then the money is split evenly amongst all officially registered competitors.

b) If one round within an elimination series has been completed, then the losers of the round shall have 33.3% divided evenly amongst them and the winners of the first round shall have 66.6% divided evenly amongst them.

In the case of a dingle elimination series, then the losers of the round shall have 50% divided evenly amongst them and the winners of the first round shall have 50% divided evenly amongst them.

c) If two rounds within an elimination series have been completed, then the losers of the first round shall have 15% divided evenly amongst them, the losers of the second round shall have 28% divided evenly amongst them and the winners of the second round shall have 57% divided evenly amongst them.

In the case of a dingle elimination series, the losers of the second round shall have 15% divided evenly amongst them, the winners of the second round and winners of the first round shall have 85% divided evenly amongst them.

(iii) Should it be decided to unofficially run competition for the incomplete discipline - up to 10% of the 50% allocated to the competitors at an event, may be offered as unofficial prize money.

14.4 Shared positions

14.4.1 When a number of competitors share a single position and their ranking order is not determined, the payment for those competitors shall be distributed as follows:

The prize money for the occupied position and the following unoccupied positions (equal in number to the competitors that end up in a single position) shall be added together, then divided by the number of the group of competitors being paid in this manner.

15 RACE NOTICE

15.1 Publication and content of the Race Notice

15.1.1 The Race Notice is a document that must be published thirty (30) days before to the first day of the event by the KWT. Exceptions to this rule may only be made with the approval of the KWT Sports Commission and/or the GKA.

15.1.2 Contents of the Race Notice

The document shall include this information:

- (i) Name of the Event Organizer, the title, place and dates;
- (ii) That the competition is sanctioned by the KWT and governed by the KWT Rulebook;
- (iii) the discipline(s) offered and the schedule;
- (iv) maximum number of elimination series;
- (v) entry conditions and numbers of entries;
- (vi) time and place of registration and conditions for advance registration;
- (vii) registration fees;
- (viii) changes to any rules of the KWT Rulebook;
- (ix) prize money to be awarded and any additional prizes;
- (x) names of the members of the technical committee (Contest Director, Head Judge and Judges).

16 SAILING INSTRUCTIONS AND OFFICIAL NOTICE BOARD

16.1 *Publication and content of the Sailing Instructions*

16.1.1 The KWT Rulebook may be supplemented by written Sailing Instructions, which have the same status as rules.

The Sailing Instructions may alter a rule by specific reference to it, but they shall not alter any rule without prior publication in the Race Notice, after written authorization from the KWT Sports Commission. The Sailing Instructions shall be posted on the Official Notice Board and any extraordinary instructions may be distributed to competitors.

16.1.2 Contents of the Sailing Instructions

The document shall include this information:

- (i) that the KWT Rulebook, the Race Notice and the Sailing Instructions will be the documents that shall govern the event;
- (ii) the schedule of the event;
- (iii) the competition area;
- (iv) the time limit for finishing;
- (v) the judging criterias and scoring system;
- (vi) the maximum number of eliminations;
- (vii) any changes to the rules.

- (viii) prize money to be awarded and any additional prizes;
- (ix) any special safety information;
- (x) the names of the Contest Director, Head Judge, Judging panel and KWT Representative.

16.1.3 Changes to the Sailing Instructions

Any changes of Sailing Instruction must be approved by the KWT Sports Commission or its Representative and shall be post a notice on the Official Notice Board at least 30 minutes before the start of the heat in which they are to apply.

16.2 Official Notice Board (ONB) and Official Flag Pole (OFP)

16.2.1 All official announcements shall be posted in writing on the Official Notice Board. All competitors' attention will be drawn to all important announcements, such as changes to Sailing Instructions.

16.2.2 The information posted on the Official Notice Board must be checked periodically by all competitors.

16.2.3 At least 15 minutes before the start of the heat, the schedule of event, competition area diagram, and heat duration shall be posted at the official Notice Board. Competitors shall check the Notice Board to know in which heat they will be taking part.

16.2.4 Official Flag Pole (OFP)

All signals shall be made from the place indicated in the Sailing Instructions or in the way indicated in the Sailing Instructions.

16.2.5. The Contest Director shall announce the weather forecast for the day, the schedule for the day and any other relevant information at the daily competitor's meeting.

16.3 Oral Instructions

16.3.1 Oral instructions may only be given if the procedure is stated in the Sailing Instructions.

17 PENALTIES AND REDRESS

17.1 Penalties

17.1.1 A competitor may be disqualified from the event by the Race Committee - even without a hearing if they hinder another competitor while competing.

17.1.2 The Race Committee may disqualify a competitor from the event for infringing the KWT Rulebook, Sailing Instructions or any governing document as described in the Sailing Instructions.

17.2 Redress

17.2.1 A request for redress, or a Head Judge decision to consider redress, shall be based on a claim or possibility that a rider / competitor's score in an elimination series has been, or may be, through no fault of their own, made significantly worse by:

- (i) injury or physical damage caused as a result of the action of another rider / competitor that was breaking a right-of-way rule, or of a vessel not racing that was required to keep clear;
- (ii) giving help (except to themselves) in compliance with rule 2.4.3; or
- (ii) an action of a rider / competitor, or a member of their crew, that resulted in a penalty under rule 2.4, or a penalty or warning under KWT disciplinary code of conduct rules.
- (iv) crashing because of the action of another rider / competitor who was breaking a right-of-way.

17.2.2 Requests for a redress shall be made in writing, identifying the reason for making the redress request. If the request is based on an incident in the racing / contest area, it shall be delivered to the race office within the protest time limit or two hours after the incident, whichever is later. Other requests shall be delivered as soon as reasonably possible after learning of the reasons for making the request. The head judge shall extend the time if there is good reason to do so.

17.2.3 If Head Judge decide that the score has been materially prejudiced in any of the circumstances set out above, they shall make as fair an arrangement as possible for all competitors concerned. The Head Judge may take action by themselves without a hearing. This may be to let the results of the heat stand, to adjust the score of the prejudiced competitor, to abandon and re-run the heat, to have a sail-off between certain competitors in the heat, to cancel the heat, to add some more time to the original heat or to adopt some other means. The Head Judge may overrule the Judge's decision if there is evidence that a competitor lost their heat because of a Judges' mistake. They may only re-run the heat, but not adjust the result.

18 ENTRY ALLOCATION AND SEEDING

18.1 Entry allocation



18.1.1 Entries into KWT events shall be allocated according to the following table:

CATEGORY	64 Riders	48 Riders	32 Riders	24 Riders	16 Riders	12 Riders
Previous year KWT Ranking	1-24	1-18	1-12	1-12	1-8	1-6
Current KWT Ranking	25-45	19-32	13-22	13-16	9-12	7-9
KWT Wildcard Ranking	46-56	33-39	23-28	17-20	13-14	10
National Qualifier Ranking	57-60	40-44	29-32	21-24	15-16	11-12
Organizer Wildcard Ranking	61-64	45-48				

18.1.2 In the case that there is no National Qualifier Ranking, the Wildcards will be allocated as follows: half for KWT and half for the Organizer.

18.1.3 One week before the event, Local Organizer Wildcards shall be approved by the KWT Sports Commission.

18.1.4 If any ranked competitor cannot compete in one KWT event due to an injury or other reasons, the empty spot will be given to the next highest ranked competitor.

18.1.5 If there isn't a national qualifier nor a wildcard ranking, competitors will be distributed in the KWT ladder according to the name drawing that shall be done by the Contest Director at the first day mandatory meeting for all competitors before the competition starts.

18.2 Seeding and Elimination Procedure

18.2.1 The Previous years KWT Ranking Seeding List for an event shall be calculated as follows:

- (i) the competitor's final position on the KWT Ranking list from the previous year, which shall be regarded as one result; the two best results over the past 12 months; and the previous year's result at that specific event, which may count twice if it is one of the two best results (if this does not exist, the next best result from the previous

12 months). This will give four results, the highest of which is discarded. In all the above instances, the positions scored by the competitor shall be added together and the competitor with the lowest score shall be seeded first and so on. In the event of a tie, the KWT tie-break rules shall be applicable.

(ii) if a top 40 ranked sailor is unable to compete at an event or events due to injury, the seeding of that sailor will be protected for a period of four months, after which time seedings will be allocated as described above.

18.2.2 Elimination shall be single, dingle or double eliminations.

18.2.3 The Elimination procedure shall be:

(i) competitors' names shall be entered on the appropriate elimination ladder for the first elimination series according to the event Seeding List and the seeding distribution table below.

(ii) If there isn't a previous year nor a current ranking, competitors will be distributed in the KWT ladder according to the name drawing that shall be done by the Contest Director at the first day mandatory meeting for all competitors before the competition starts.

(iii) "Byes," if any, shall be positioned so that they are allocated to the most highly ranked competitors.

(iv) competitors shall sail one against one in pairs, or in groups of up to 8 determined by the elimination ladder. The declared winner of each pair or the top half of the large groups shall advance on the elimination ladder. Once a round is started, the format shall stay the same until that round is completed. The format refers to either one on one or groups with the top half advancing.

18.3 Heat distribution

64 Competitors Single		48 Competitors Single		32 Competitors Single	
Heat No.	Competitor	Heat No.	Competitor	Heat No.	Competitor
1a	11 vs 54	1a	38 vs 27	1a	6 vs 27
1b	22 vs 43	1b	43 vs 22		
2a	6 vs 59	2a	35 vs 30	1b	11 vs 22
2b	27 vs 38	2b	46 vs 19		
3a	14 vs 51	3a	39 vs 26	2a	3 vs 30
3b	19 vs 46	3b	42 vs 23		
4a	3 vs 62	4a	34 vs 31	2b	14 vs 19
4b	30 vs 35	4b	47 vs 18		
5a	10 vs 55	5a	37 vs 28	3a	7 vs 26
5b	23 vs 42	5b	44 vs 21		
6a	7 vs 58	6a	36 vs 29	3b	10 vs 23
6b	26 vs 39	6b	45 vs 20		

7a	15 vs 50	7a	40 vs 25	4a	2 vs 31
7b	18 vs 47	7b	41 vs 24		
8a	2 vs 63	8a	33 vs 32	4b	15 vs 18
8b	31 vs 34	8b	48 vs 17		
9a	12 vs 53	9a	6 vs W1a	5a	5 vs 28
9b	21 vs 44	9b	11 vs W1b		
10a	5 vs 60	10a	3 vs W2a	5b	12 vs 21
10b	28 vs 37	10b	14 vs W2b		
11a	13 vs 52	11a	7 vs W3a	6a	4 vs 29
11b	20 vs 45	11b	10 vs W3b		
12a	4 vs 61	12a	2 vs W4a	6b	13 vs 20
12b	29 vs 36	12b	15 vs W4b		
13a	9 vs 56	13a	5 vs W5a	7a	8 vs 25
13b	24 vs 41	13b	12 vs W5b		
14a	8 vs 57	14a	4 vs W6a	7b	9 vs 24
14b	25 vs 40	14b	13 vs W6b		
15a	16 vs 49	15a	8 vs W7a	8a	1 vs 32
15b	17 vs 48	15b	9 vs W7b		
16a	1 vs 64	16a	1 vs W8a	8b	16 vs 17
16b	32 vs 33	16b	16 vs W8b		

24 Competitors Single		16 Competitors Single		12 Competitors Single	
Heat No.	Competitor	Heat No.	Competitor	Heat No.	Competitor
1a	11 vs 54	1a	3 vs 14	1a	10 vs 7
1b	22 vs 43				
2a	6 vs 59	1b	6 vs 11	1b	11 vs 6
2b	27 vs 38				
3a	14 vs 51	2a	2 vs 15	2a	9 vs 8
3b	19 vs 46				
4a	3 vs 62	2b	7 vs 10	2b	12 vs 5
4b	30 vs 35				
5a	10 vs 55	3a	4 vs 13	3a	2 vs W1a
5b	23 vs 42				
6a	7 vs 58	3b	5 vs 12	3b	3 vs W1b
6b	26 vs 39				
7a	15 vs 50	4a	1 vs 16	4a	1 vs W2a
7b	18 vs 47				
8a	2 vs 63	4b	8 vs 9	4b	4 vs W2b
8b	31 vs 34				
9a	12 vs 53				
9b	21 vs 44				
10a	5 vs 60				
10b	28 vs 37				
11a	13 vs 52				
11b	20 vs 45				
12a	4 vs 61				
12b	29 vs 36				
13a	9 vs 56				
13b	24 vs 41				
14a	8 vs 57				
14b	25 vs 40				
15a	16 vs 49				
15b	17 vs 48				
16a	1 vs 64				
16b	32 vs 33				

48 Competitors Dingle		24 Competitors Dingle		12 Competitors Dingle	
Heat No.	Competitor	Heat No.	Competitor	Heat No.	Competitor
1	11 vs 22 vs 38	1	6 vs 11 vs 19	1	3 vs 6 vs 10
2	6 vs 27 vs 43	2	3 vs 14 vs 22	2	2 vs 7 vs 11
3	14 vs 19 vs 35	3	7 vs 10 vs 18	3	4 vs 5 vs 9
4	3 vs 30 vs 46	4	2 vs 15 vs 23	4	1 vs 8 vs 12
5	10 vs 23 vs 39	5	5 vs 12 vs 20		
6	7 vs 26 vs 42	6	4 vs 13 vs 21		
7	15 vs 18 vs 34	7	8 vs 9 vs 17		
8	2 vs 31 vs 47	8	1 vs 16 vs 24		
9	12 vs 21 vs 37				
10	5 vs 28 vs 44				
11	13 vs 20 vs 36				
12	4 vs 29 vs 45				
13	9 vs 24 vs 40				
14	8 vs 25 vs 41				
15	16 vs 17 vs 33				
16	1 vs 32 vs 48				

(i) Heats may be run with either 2, 4 or 8 competitors in each heat or using the dingle elimination system at the discretion of the KWT Sports Commission.

19 ELIMINATION LADDERS AND SCORING

19.1 *Elimination ladders*

19.1.1 The elimination ladder used for KWT shall be Single, Double or Dingle elimination.

19.1.2 KWT 64 Riders Single Elimination:



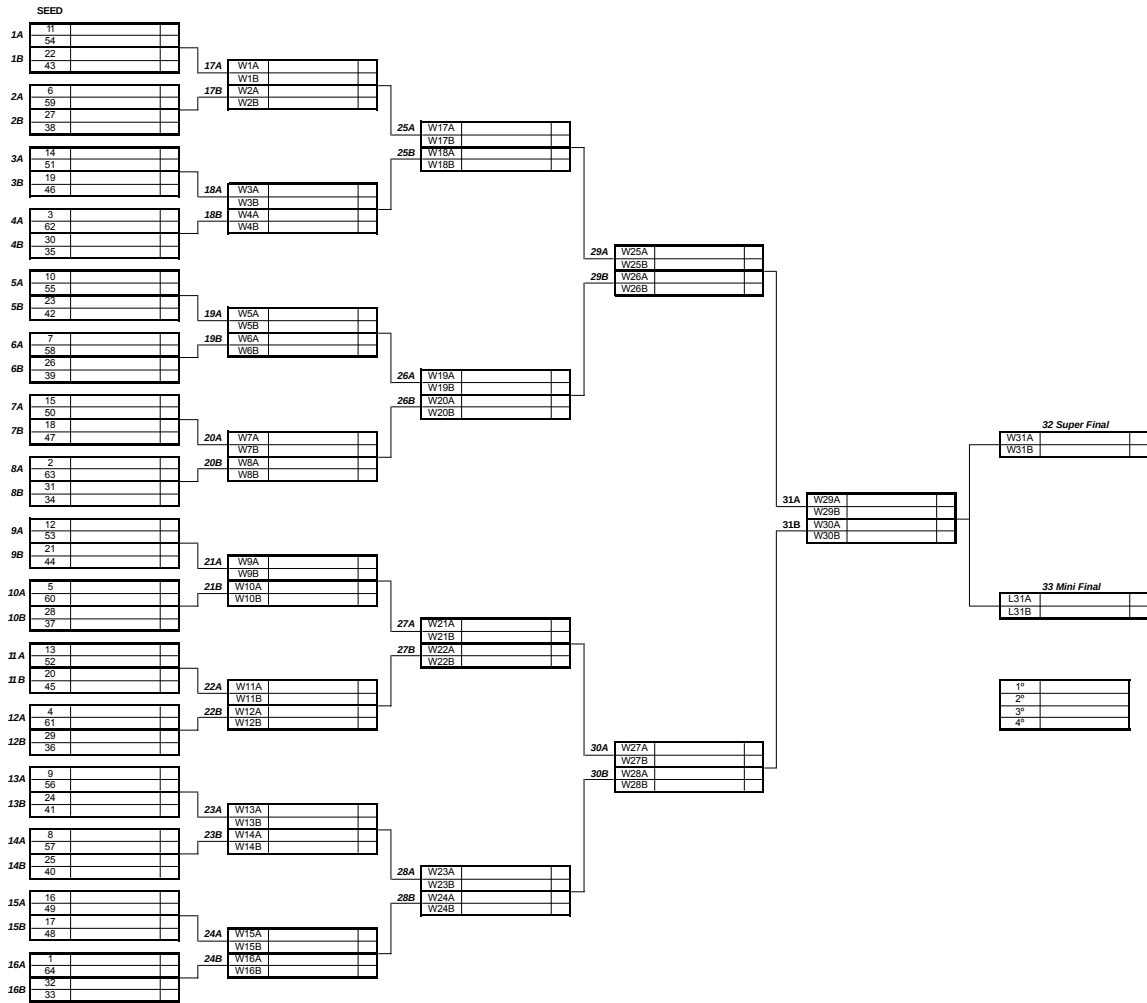

19.1.3 KWT 64 Riders Double Elimination:

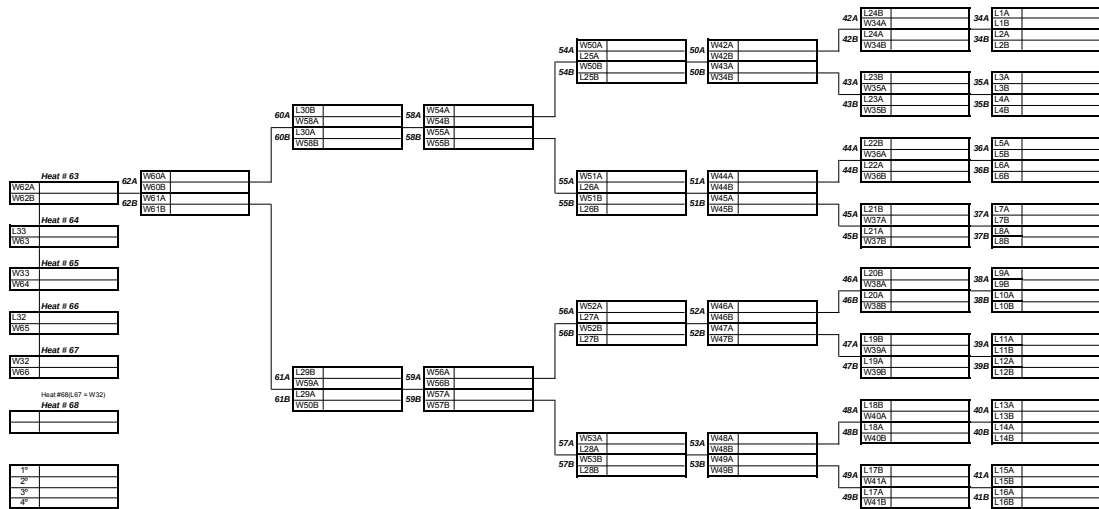

(i) Losers from the single elimination are placed according to where they were knocked out i.e. the losers of heat 1 compete in heat 34a and the losers of heat 2 compete in 34b.

19.1.4 KWT 48 Riders Single Elimination

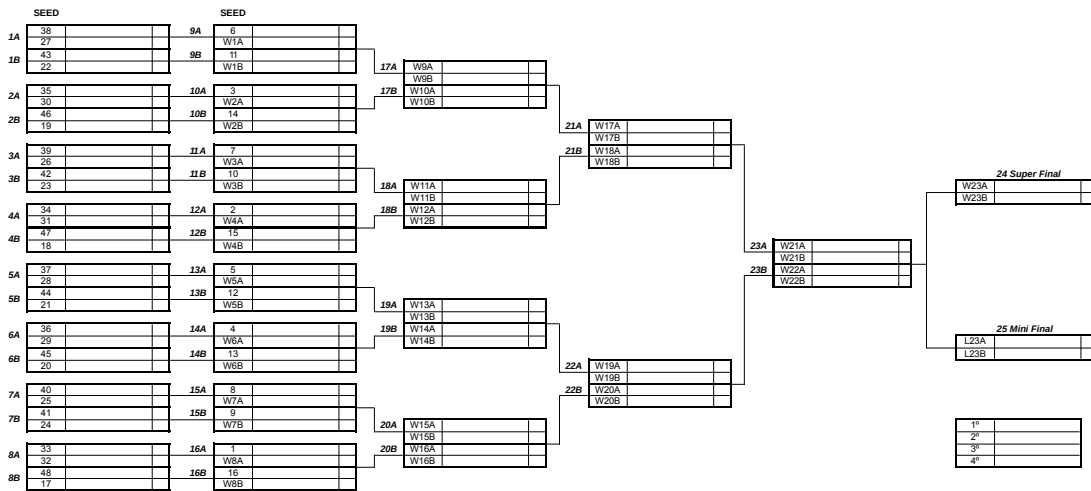

19.1.5 KWT 48 Riders Double Elimination:

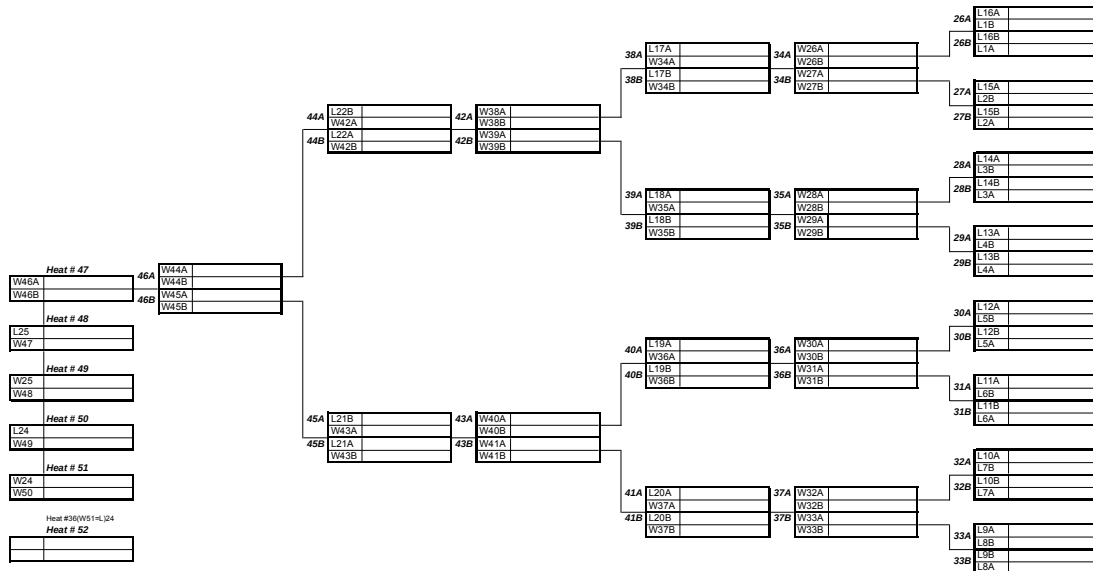

(i) Losers from the single elimination are placed as follows: the loser of heat 16a competes in heat 26a against the loser of heat 1b and the loser of heat 16b competes in heat 26b against the

loser of heat 1a. The loser of heat 15a competes in heat 27a against the loser of heat 2b and the loser of heat 15b competes in heat 27b against the loser of heat 2a, and so on.

19.1.6 KWT 32 Riders Single Elimination:

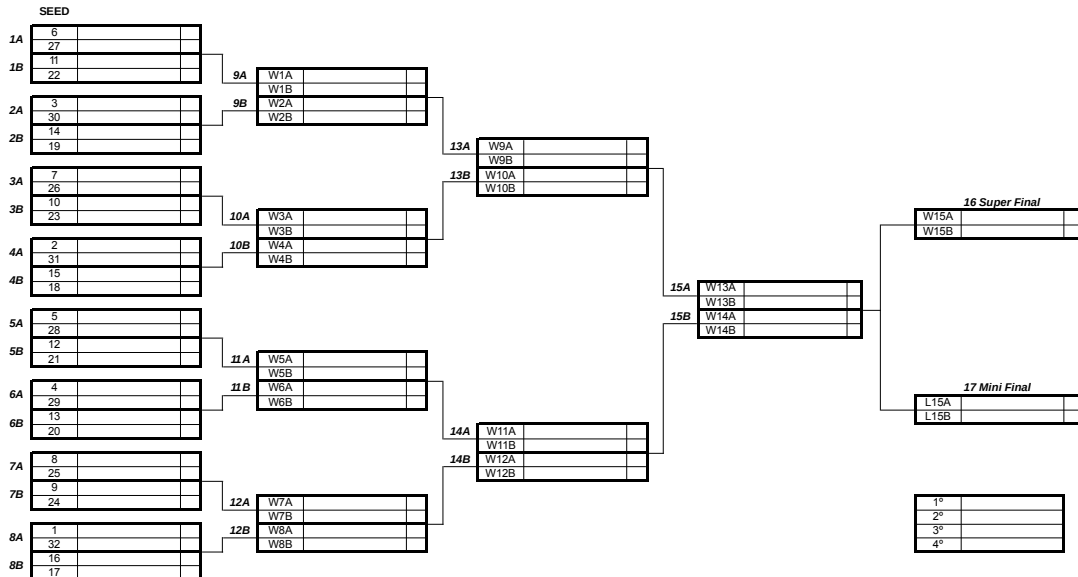

19.1.7 KWT 32 Riders Double Elimination:

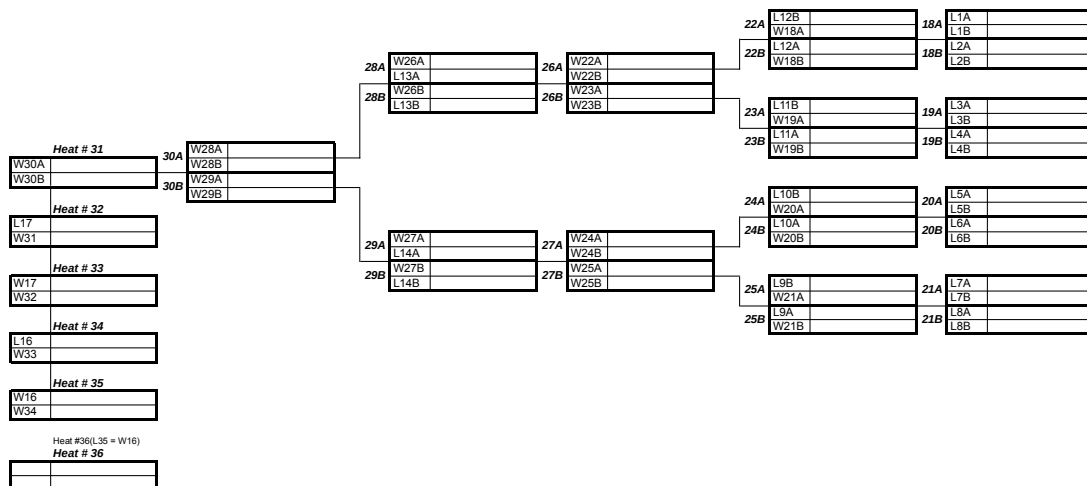

- (i) Losers from the single elimination are placed according to where they were knocked out i.e. the losers of heat 1 compete in heat 18a and the losers of heat 2 compete in 18b.

19.1.8 KWT 24 Riders Single Elimination

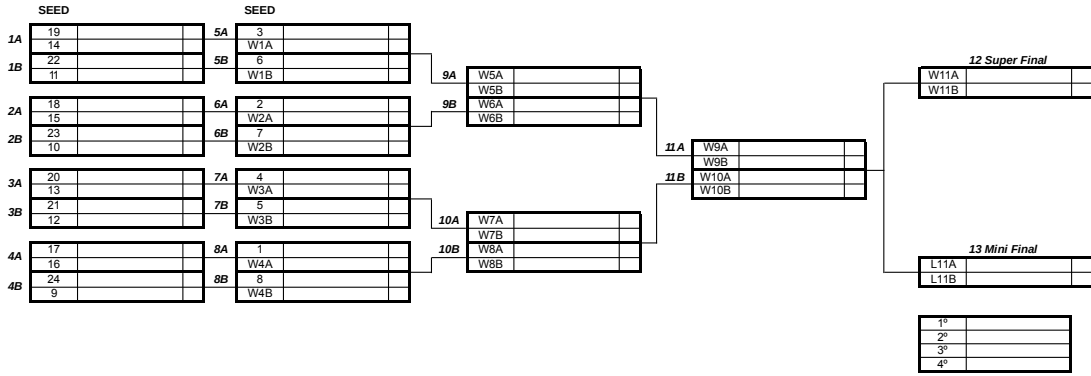

19.1.9 KWT 24 Riders Double Elimination:

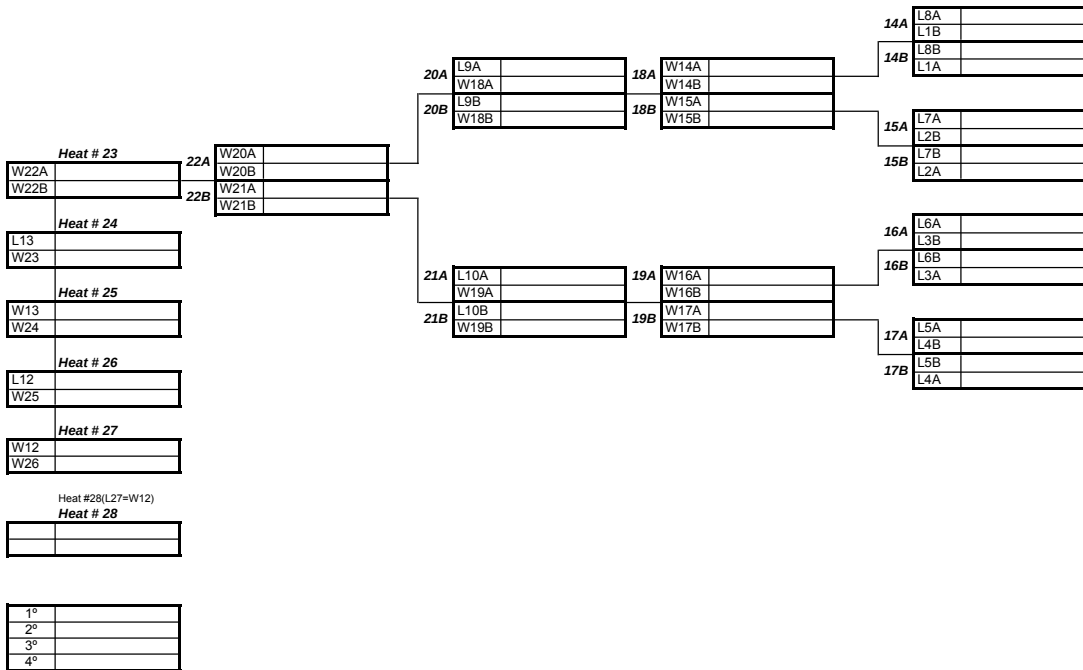

(i) Losers from the single elimination are placed as follows: the loser of heat 8a competes in heat 14a against the loser of heat 1b and the loser of heat 8b competes in heat 14b against the loser of heat 1a. The loser of heat 7a competes in heat 15a against the loser of heat 2b and the loser of heat 7b competes in heat 15b against the loser of heat 2a, and so on.

19.1.10 KWT 16 Riders Single Elimination:

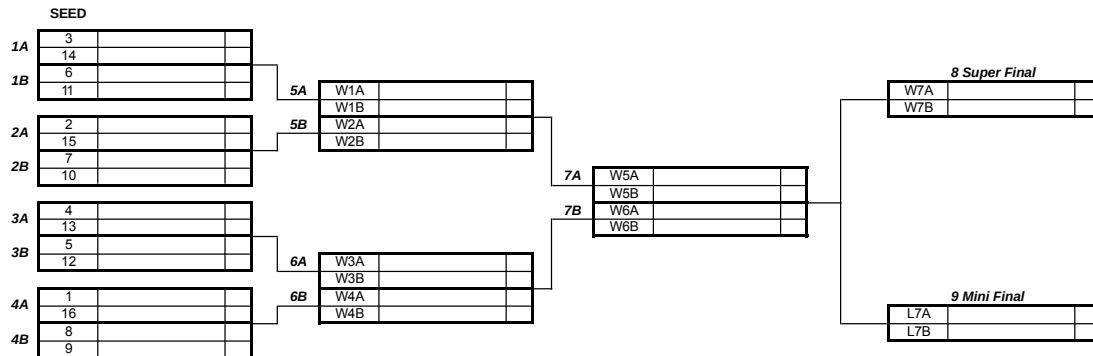

19.1.11 KWT 16 Riders Double Elimination:

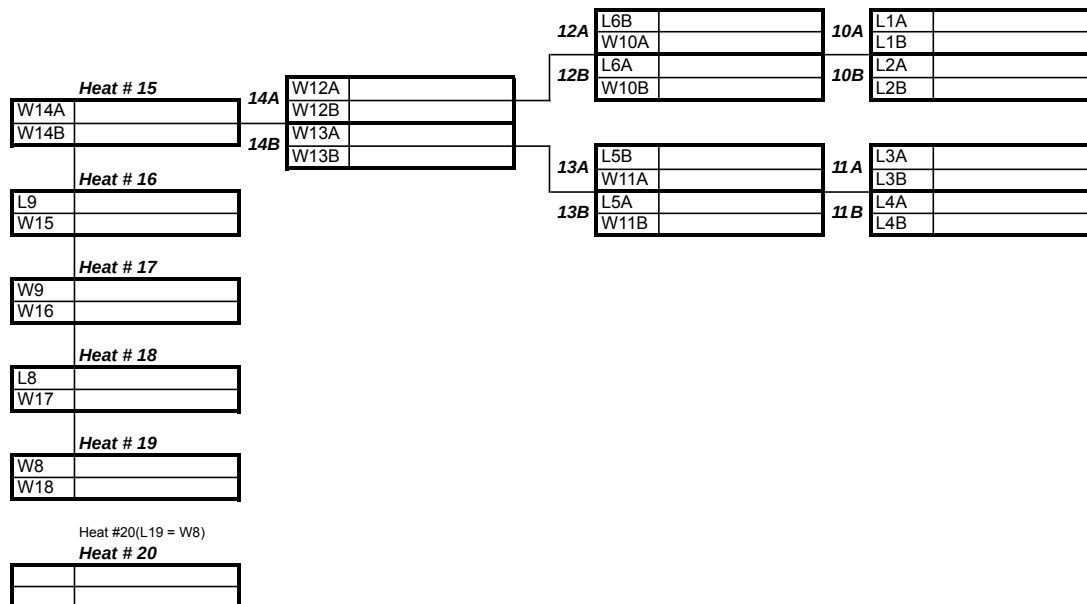

(i) Losers from the single elimination are placed according to where they were knocked out i.e. the losers of heat 1 compete in heat 10a and the losers of heat 2 compete in 10b.

19.1.12 KWT 12 Riders Single Elimination

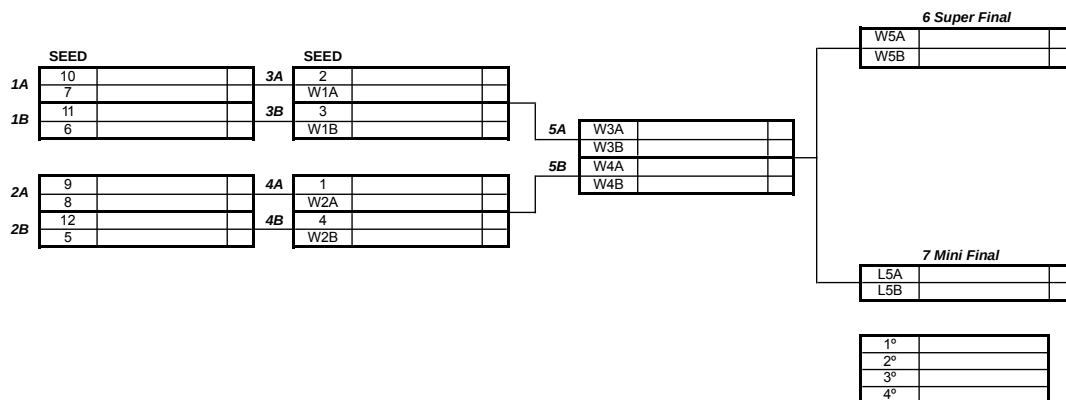

19.1.13 KWT 12 Riders Double Elimination:

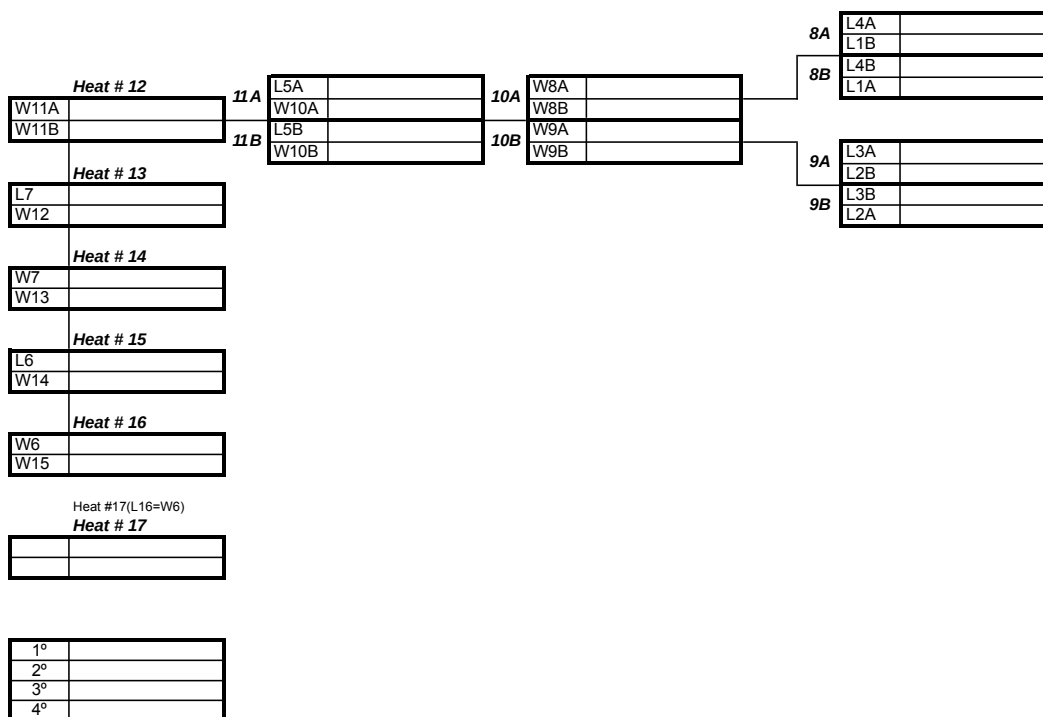

(i) Losers from the single elimination are placed as follows: the loser of heat 4a competes in heat 8a against the loser of heat 1b and the loser of heat 4b competes in heat 8b against the loser of heat 1a. The loser of heat 3a competes in heat 9a against the loser of heat 2b and the loser of heat 3b competes in heat 9b against the loser of heat 2a, and so on.

19.1.14 KWT 12 Riders Dingle Elimination

Heat	Seed	Name
1	3	
	6	
	10	
2	2	
	7	
	11	
3	4	
	5	
	9	
4	1	
	8	
	12	

HEAT # 5	
2ND#3	
3RD#2	
2ND#4	
3RD#1	

HEAT # 6	
2ND#1	
3RD#4	
2ND#2	
3RD#3	

HEAT # 7	
2ND#1	
3RD#4	
2ND#2	
3RD#3	

HEAT # 8	
2ND#3	
3RD#2	
2ND#4	
3RD#1	

HEAT # 9	
W1	
W5	
W2	
W6	

HEAT # 10	
W3	
W7	
W4	
W8	

HEAT # 11	
W3	
W7	
W4	
W8	

HEAT # 12	
W3	
W7	
W4	
W8	

HEAT # 13	
W9	
W10	
W11	
W12	

HEAT # 14	
W9	
W10	
W11	
W12	

WINNERS FINAL HEAT # 15	
W13	
W14	

HEAT # 16 MINI FINAL	
L13	
L14	

19.1.15 KWT 24 Riders Dingle Elimination

Heat	Seed	Name
1	6	
	11	
	19	
	3	
2	14	
	22	
	7	
3	10	
	18	
	2	
4	15	
	23	
	5	
5	12	
	20	
	4	
6	13	
	21	
	9	
7	9	
	17	
	1	
8	16	
	24	

HEAT # 9	
2ND#5	
3RD#2	
2ND#3	
3RD#1	

HEAT # 10	
2ND#7	
3RD#4	
2ND#8	
3RD#3	

HEAT # 11	
2ND#1	
3RD#6	
2ND#2	
3RD#5	

HEAT # 12	
2ND#1	
3RD#6	
2ND#2	
3RD#5	

HEAT # 13	
2ND#1	
3RD#6	
2ND#2	
3RD#5	

HEAT # 14	
2ND#3	
3RD#8	
2ND#4	
3RD#7	

HEAT # 15	
2ND#3	
3RD#8	
2ND#4	
3RD#7	

HEAT # 16	
2ND#3	
3RD#8	
2ND#4	
3RD#7	

HEAT # 17	
W1	
W9	
W2	
W10	

HEAT # 18	
W1	
W9	
W2	
W10	

HEAT # 19	
W3	
W11	
W4	
W12	

HEAT # 20	
W3	
W11	
W4	
W12	

HEAT # 21	
W5	
W13	
W6	
W14	

HEAT # 22	
W5	
W13	
W6	
W14	

HEAT # 23	
W7	
W15	
W8	
W16	

HEAT # 24	
W7	
W15	
W8	
W16	

HEAT # 25	
W17	
W18	
W19	
W20	

HEAT # 26	
W17	
W18	
W19	
W20	

HEAT # 27	
W21	
W22	
W23	
W24	

HEAT # 28	
W21	
W22	
W23	
W24	

HEAT # 29	
W24	
W26	
W27	
W28	

HEAT # 30	
W24	
W26	
W27	
W28	

WINNERS FINAL HEAT # 31	
W29	
W30	

HEAT # 32 MINI FINAL	
L29	
L30	

HEAT # 33	
L1	
L2	
L3	
L4	

19.1.16 KWT 48 Riders Dingle Elimination

Heat	Seed	Name
1	11	
	22	
	38	
	6	
2	27	
	43	
3	14	
	19	
	35	
4	3	
	30	
	46	
5	10	
	23	
	39	
7	7	
	26	
	42	
15	15	
7	18	
	34	
8	2	
	31	
	47	
9	12	
	21	
	37	
10	5	
	28	
	44	
11	13	
	20	
	36	
12	4	
	29	
	45	
13	9	
	24	
	40	
14	8	
	25	
	41	
15	16	
	17	
	33	
16	1	
	32	
	48	

HEAT # 17		HEAT # 33	
2NDP9		W1	
3RDQ2		W17	
2NDP10		W2	
3RDH1		W18	

HEAT # 18		HEAT # 34	
2NDH11		W3	
3RDH4		W19	
2NDH12		W4	
3RDH3		W20	

HEAT # 19		HEAT # 35	
2NDH11		W3	
3RDH4		W19	
2NDH12		W4	
3RDH3		W20	

HEAT # 20		HEAT # 36	
2NDH13		W5	
3RDH5		W21	
2NDH14		W6	
3RDH5		W22	

HEAT # 21		HEAT # 37	
2NDH13		W5	
3RDH5		W21	
2NDH14		W6	
3RDH5		W22	

HEAT # 22		HEAT # 38	
2NDH15		W7	
3RDH6		W23	
2NDH16		W8	
3RDH7		W24	

HEAT # 23		HEAT # 39	
2NDH15		W7	
3RDH6		W23	
2NDH16		W8	
3RDH7		W24	

HEAT # 24		HEAT # 40	
2NDH1		W9	
3RDH9		W25	
2NDH2		W10	
3RDH9		W26	

HEAT # 25		HEAT # 41	
2NDH1		W9	
3RDH9		W25	
2NDH2		W10	
3RDH9		W26	

HEAT # 26		HEAT # 42	
2NDH3		W11	
3RDH12		W27	
2NDH4		W12	
3RDH11		W28	

HEAT # 27		HEAT # 43	
2NDH3		W11	
3RDH12		W27	
2NDH4		W12	
3RDH11		W28	

HEAT # 28		HEAT # 44	
2NDH5		W13	
3RDH14		W29	
2NDH6		W14	
3RDH13		W30	

HEAT # 29		HEAT # 45	
2NDH5		W13	
3RDH14		W29	
2NDH6		W14	
3RDH13		W30	

HEAT # 30		HEAT # 46	
2NDH7		W15	
3RDH16		W31	
2NDH8		W16	
3RDH15		W32	

HEAT # 31		HEAT # 47	
2NDH7		W15	
3RDH16		W31	
2NDH8		W16	
3RDH15		W32	

HEAT # 32		HEAT # 48	
2NDH9		W17	
3RDH18		W33	
2NDH10		W18	
3RDH17		W34	

HEAT # 49	
W33	
W34	
W35	
W36	

HEAT # 50	
W37	
W38	
W39	
W40	

HEAT # 51	
W37	
W38	
W39	
W40	

HEAT # 52	
W37	
W38	
W39	
W40	

HEAT # 53	
W41	
W42	
W43	
W44	

HEAT # 54	
W41	
W42	
W43	
W44	

HEAT # 55	
W45	
W46	
W47	
W48	

HEAT # 56	
W45	
W46	
W47	
W48	

HEAT # 57	
W49	
W50	
W51	
W52	

HEAT # 58	
W49	
W50	
W51	
W52	

HEAT # 59	
W57	
W58	
W59	
W60	

HEAT # 60	
W53	
W54	
W55	
W56	

HEAT # 61	
W57	
W58	
W59	
W60	

HEAT # 62	
W57	
W58	
W59	
W60	

WINNERS/FINAL	
HEAT # 63	
W61	
W62	

HEAT # 64	
L61	
L62	

HEAT # 64	
MINI FINAL	
15	
29	
39	
46	

(i) In a dingle elimination the winners of the first round heats advance immediately to the third round, whilst the second and third placed sailors are re-seeded into the second round

19.2 Heat Schedule

19.2.1 The schedule of heats shall be posted at the Official Notice Board. It shall be sole responsibility of each competitor to know in which heat they will be taking part.

19.3 4 Riders Heat

19.3.1 In a 4 riders heat the winners will advance with the first placed competitor in heat 1 advancing to the uppermost slot available in the next round and the second placed sailor in heat 1 advancing to the lowermost slot available in the next round.

19.3.2 In heat 2, the first placed competitor shall advance to the next lowest slot available in the next round with the second placed competitor advancing to the next highest slot available in the next round and so on.

19.3.3 In 4 riders heat the Race Director and / or the Head Judge may decide that the semi final heat becomes the 4 riders final after consultation with the KWT Representative.

19.4 Male Heats Double Elimination

19.4.1 In Double Elimination, where the Single elimination has been run with 4 male heats and the Double elimination will also be run with four male heats, the losers from round one shall be re seeded into the Double elimination as follows:

(a) The third place sailor in heats 1 to 16 shall be seeded into the uppermost free slot in the first heat of the first round of the Double elimination, with the third place of heat 1 advancing to the uppermost free slot in heat 34a, third place of heat 2 advancing to the uppermost free slot in heat 34b and so on.

(b) The fourth place sailor in heats 1 to 16 shall be seeded into the lowest free slot in the last heat of the first round of the Double elimination, with the fourth place of heat 1 advancing to the Lowest free slot in heat 41b, fourth place of heat 2 advancing to the lowest free slot in heat 41a and so on.

(c) The seeding and distribution of competitors in Double Elimination formats where more than 2 competitors compete in a heat may be changed by the Race Director after consultation with the KWT Representative, if it is considered in the interests of fairness of competition.

19.5 Discipline Scoring

19.5.1 There shall be no more than 1 single / dingle / double eliminations at each KWT event.

19.5.2 The minimum number of elimination series to constitute a valid score at an event and in order to distribute prize money is one (1) KWT elimination ladder - where the fleet has been eliminated to the top sixteen riders (64 Single and/or 48 Single / Dingle); top eight riders (32 Single and /or 24 Single / Dingle) and / or four riders (16 Single and / or 12 Single / Dingle).

19.5.3 Finishing positions in Single Elimination shall be scored as follows:

64 Riders:

Finishing Position	Points
Heat 32 - 1 st , 2 nd	0.7, 2
Heat 33 - 1 st , 2 nd	3, 4
Heats 29 - 30	5
Heats 25 - 28	9
Heats 17 - 24	17
Heats 1 - 16	33

48 Riders:

Finishing Position	Points
Heat 24 - 1 st , 2 nd	0.7, 2
Heat 25 - 1 st , 2 nd	3, 4
Heats 21 – 22	5
Heats 17 – 20	9
Heats 9 – 16	17
Heats 1 - 8	33

24 Riders:

Finishing Position	Points
Heat 12 - 1 st , 2 nd	0.7, 2
Heat 13 - 1 st , 2 nd	3, 4
Heats 9 – 10	5
Heats 5 – 8	9
Heats 1 – 4	17

32 Riders:

Finishing Position	Points
Heat 16 - 1 st , 2 nd	0.7, 2
Heat 17 - 1 st , 2 nd	3, 4
Heats 13 - 14	5
Heats 9 - 12	9
Heats 1 - 8	17

16 Riders:

Finishing Position	Points
Heat 8 - 1 st , 2 nd	0.7, 2
Heat 9 - 1 st , 2 nd	3, 4
Heats 5 - 6	5
Heats 1 - 4	9

12 Riders:

Finishing Position	Points
Heat 6 - 1 st , 2 nd	0.7, 2
Heat 7 - 1 st , 2 nd	3, 4
Heats 3 - 4	5
Heats 1 - 2	9

19.5.4 Finishing positions in Double Elimination shall be scored as follows:

64 Riders:



Finishing Position	Points
Heat 67 (or 68) 1 st , 2 nd	0.7, 2
Heat 66	3
Heat 65	4
Heat 64	5
Heat 63	6
Heat 62	7
Heats 60 - 61	9
Heats 58 - 59	13
Heats 54 - 57	17
Heats 50 - 53	25
Heats 42 - 49	33
Heats 34 - 41	49

48 Riders:

Finishing Position	Points
Heat 51 (or 52) 1 st , 2 nd	0.7, 2
Heat 50	3
Heat 49	4
Heat 48	5
Heat 47	6
Heat 46	7
Heats 44 - 45	9
Heats 42 - 43	13
Heats 38 - 41	17
Heats 34 - 37	25
Heats 26 - 33	33

32 Riders:

Finishing Position	Points
Heat 35 (or 36) 1 st , 2 nd	0.7, 2
Heat 34	3
Heat 33	4
Heat 32	5
Heat 31	6
Heat 30	7
Heats 28 - 29	9
Heats 26 - 27	13
Heats 22 - 25	17
Heats 18 - 21	25

24 Riders:

Finishing Position	Points
Heat 27 (or 28) 1 st , 2 nd	0.7, 2
Heat 26	3
Heat 25	4

Heat 24	5
Heat 23	6
Heat 22	7
Heats 20 - 21	9
Heats 18 - 19	13
Heats 14 - 17	17

16 Riders:

Finishing Position	Points
Heat 19 (or 20) 1 st , 2 nd	0.7, 2
Heat 18	3
Heat 17	4
Heat 16	5
Heat 15	6
Heat 14	7
Heats 12 - 13	9
Heats 10 - 11	13

12 Riders:

Finishing Position	Points
Heat 15 (or 16) 1 st , 2 nd	0.7, 2
Heat 14	3
Heat 13	4
Heat 12	5
Heat 11	6
Heat 10	7
Heats 8 - 9	9

19.5.5 Finishing positions in Single Elimination with 4 male heats shall be scored as follows:

64 Riders:

Finishing Position	Points
Heat 32 - 1 st , 2 nd	0.7, 2
Heat 33 - 1 st , 2 nd	3, 4
Heat 31 (if 32 and 33 not sailed)	0.7, 2, 3, 4
Heats 29 – 30, 3 rd , 4 th	5, 7
Heats 25 – 28, 3 rd , 4 th	9, 13
Heats 17 – 24, 3 rd , 4 th	17, 25
Heats 1 – 16, 3 rd , 4 th	33, 49

48 Riders:

Finishing Position	Points
--------------------	--------



Heat 24 - 1 st , 2 nd	0.7, 2
Heat 25 - 1 st , 2 nd	3, 4
Heat 23 (if 32 and 33 not sailed)	0.7, 2, 3, 4
Heats 21 – 22, 3 rd , 4 th	5, 7
Heats 17 – 20, 3 rd , 4 th	9, 13
Heats 9 – 16, 3 rd , 4 th	17, 25
Heats 1 – 8, 3 rd , 4 th	33, 41

32 Riders:

Finishing Position	Points
Heat 16 - 1 st , 2 nd	0.7, 2
Heat 17 - 1 st , 2 nd	3, 4
Heat 15 (if 16 and 17 not sailed)	0.7, 2, 3, 4
Heats 13 – 14, 3 rd , 4 th	5, 7
Heats 9 – 12, 3 rd , 4 th	9, 13
Heats 1 – 8, 3 rd , 4 th	17, 25

24 Riders:

Finishing Position	Points
Heat 12 - 1 st , 2 nd	0.7, 2
Heat 13 - 1 st , 2 nd	3, 4
Heat 11 (if 12 and 13 not sailed)	0.7, 2, 3, 4
Heats 9 – 10, 3 rd , 4 th	5, 7
Heats 5 – 8, 3 rd , 4 th	9, 13
Heats 1 – 4, 3 rd , 4 th	17, 21

16 Riders:

Finishing Position	Points
Heat 8 - 1 st , 2 nd	0.7, 2
Heat 9 - 1 st , 2 nd	3, 4
Heat 7 (if 8 and 9 not sailed)	0.7, 2, 3, 4
Heats 5 – 6, 3 rd , 4 th	5, 7
Heats 1 – 4, 3 rd , 4 th	9, 13

12 Riders:

Finishing Position	Points
Heat 6 - 1 st , 2 nd	0.7, 2
Heat 7 - 1 st , 2 nd	3, 4
Heat 5 (if 6 and 7 not sailed)	0.7, 2, 3, 4

Heats 3 – 4, 3 rd , 4 th	5, 7
Heats 1 – 2, 3 rd , 4 th	9, 11

19.5.6. Finishing positions in Double Elimination with 4 man heats shall be scored as follows:

64 Riders:

Finishing Position	Points
Heat 67 (or 68) 1 st , 2 nd	0.7, 2
Heat 66	3
Heat 65	4
Heat 64	5
Heat 63	6
Heat 62, 3 rd , 4 th	7, 8
Heats 60 – 61, 3 rd , 4 th	9, 11
Heats 58 – 59, 3 rd , 4 th	13,15
Heats 54 – 57, 3 rd , 4 th	17, 21
Heats 50 – 53, 3 rd , 4 th	25, 29
Heats 42 – 49, 3 rd , 4 th	33, 41
Heats 34 – 41, 3 rd , 4 th	49, 57

48 Riders:

Finishing Position	Points
Heat 51 (or 52) 1 st , 2 nd	0.7, 2
Heat 50	3
Heat 49	4
Heat 48	5
Heat 47	6
Heat 46, 3 rd , 4 th	7, 8
Heats 44 – 45, 3 rd , 4 th	9, 11
Heats 42 – 43, 3 rd , 4 th	13,15
Heats 38 – 41, 3 rd , 4 th	17, 21
Heats 34 – 37, 3 rd , 4 th	25, 29
Heats 26 – 33, 3 rd , 4 th	33, 41

32 Riders:

Finishing Position	Points
Heat 35 (or 36) 1 st , 2 nd	0.7, 2
Heat 34	3
Heat 33	4
Heat 32	5
Heat 31	6
Heat 30, 3 rd , 4 th	7, 8
Heats 28 – 29, 3 rd , 4 th	9, 11
Heats 26 – 27, 3 rd , 4 th	13,15

Heats 22 – 25, 3 rd , 4 th	17, 21
Heats 18 – 21, 3 rd , 4 th	25, 29

24 Riders:

Finishing Position	Points
Heat 27 (or 28) 1 st , 2 nd	0.7, 2
Heat 26	3
Heat 25	4
Heat 24	5
Heat 23	6
Heat 22, 3 rd , 4 th	7, 8
Heats 20 – 21, 3 rd , 4 th	9, 11
Heats 18 – 19, 3 rd , 4 th	13,15
Heats 14 – 17, 3 rd , 4 th	17, 21

16 Riders:

Finishing Position	Points
Heat 19 (or 20) 1 st , 2 nd	0.7, 2
Heat 18	3
Heat 17	4
Heat 16	5
Heat 15	6
Heat 14, 3 rd , 4 th	7, 8
Heats 12 – 13, 3 rd , 4 th	9, 11
Heats 10 – 11, 3 rd , 4 th	13,15

12 Riders:

Finishing Position	Points
Heat 15 (or 16) 1 st , 2 nd	0.7, 2
Heat 14	3
Heat 13	4
Heat 12	5
Heat 11	6
Heat 10, 3 rd , 4 th	7, 8
Heats 8 – 9, 3 rd , 4 th	9, 11

19.5.7 Finishing positions in Dingle Elimination shall be scored as follows:

48 Riders:

Finishing Position	Points
Heat 63 - 1 st , 2 nd	0.7, 2
Heat 64 - 1 st , 2 nd	3, 4
Heats 57 - 60	5
Heats 49 - 56	9
Heats 33 - 48	17

Heats 17 - 32	33
---------------	----

24 Riders:

Finishing Position	Points
Heat 31 - 1 st , 2 nd	0.7, 2
Heat 32 - 1 st , 2 nd	3, 4
Heats 25 - 28	5
Heats 17 - 24	9
Heats 9 - 16	17

12 Riders:

Finishing Position	Points
Heat 15 - 1 st , 2 nd	0.7, 2
Heat 16 - 1 st , 2 nd	3, 4
Heats 9 - 12	5
Heats 5 - 8	9

19.5.8 Finishing positions in Dingle Elimination with 4 man heats shall be scored as follows:

48 Riders:

Finishing Position	Points
Heat 63 - 1 st , 2 nd	0.7, 2
Heat 64 - 1 st , 2 nd	3, 4
Heat 61 - 62, 1 st , 2 nd , 3 rd , 4 th (if 63 and 64 not sailed)	0.7, 2, 3, 4
Heats 57 - 60, 3 rd , 4 th	5, 7
Heats 49 - 56, 3 rd , 4 th	9, 13
Heats 33 - 48, 3 rd , 4 th	17, 25
Heats 17 - 32, 3 rd , 4 th	33, 41

24 Riders:

Finishing Position	Points
Heat 31 - 1 st , 2 nd	0.7, 2
Heat 32 - 1 st , 2 nd	3, 4
Heat 29 - 30, 1 st , 2 nd , 3 rd , 4 th (if 31 and 32 not sailed)	0.7, 2, 3, 4
Heats 25 - 28, 3 rd , 4 th	5, 7
Heats 17 - 24, 3 rd , 4 th	9, 13
Heats 9 - 16, 3 rd , 4 th	17, 21

12 Riders:

Finishing Position	Points
Heat 15 - 1 st , 2 nd	0.7, 2
Heat 16 - 1 st , 2 nd	3, 4
Heat 13 - 14, 1 st , 2 nd , 3 rd , 4 th (if 15 and 16 not sailed)	0.7, 2, 3, 4
Heats 9 - 12, 3 rd , 4 th	5, 7
Heats 5 - 8, 3 rd , 4 th	9, 11

19.5.9 Scoring of incomplete elimination series

When the minimum number of heats for a valid KWT elimination series has been completed but not all places have been determined, competitors qualified for heats which have not been run shall be awarded as follows:

Single 64 Riders:

Finishing Position	Points
Heat 32	1.3
Heat 33	3.5
Heat 31	2.4
Heats 29 - 30	4.4
Heats 25 - 28	8

Single 48 Riders:

Finishing Position	Points
Heat 24	1.3
Heat 25	3.5
Heat 23	2.4
Heats 21 - 22	4.4
Heats 17 - 20	8

Single 32 Riders:

Finishing Position	Points
Heat 16	1.3
Heat 17	3.5
Heat 15	2.4
Heats 13 - 14	4.4

Single 24 Riders:

Finishing Position	Points
Heat 12	1.3
Heat 13	3.5
Heat 11	2.4
Heats 9 - 10	4.4

Single 16 Riders:

Finishing Position	Points
Heat 8	1.3
Heat 9	3.5
Heat 7	2.4

Single 12 Riders:

Finishing Position	Points
Heat 6	1.3
Heat 7	3.5
Heat 5	2.4

Dingle 48:

Finishing Position	Points
Heat 63	1.3
Heat 64	3.5
Heats 61 - 62	2.4
Heats 57 - 60	4.4
Heats 49 - 56	8

Dingle 24:

Finishing Position	Points
Heat 31	1.3
Heat 32	3.5
Heat 29 - 30	2.4
Heats 25 - 28	4.4

Dingle 12:

Finishing Position	Points
Heat 15	1.3
Heat 16	3.5
Heat 13 - 14	2.4

19.5.10 In Double Elimination, final positions are those achieved in the actual heats on the Double Elimination flowchart. If a Double Elimination is scheduled but only the winner side is held, this shall be the valid result of the competition. If the losers side of the double elimination is only partly completed, the finer grid results of each completed column (or round) of the loser side shall count, in combination with the remainder of the winners' side.

20 COMPETITION FORMAT AND PROCEDURE

20.1 *Competition Format*

20.1.1 Identification of competitors

Colored lycra vest will be given by the Beach Marshall located at the official Flag pole two (2) heats prior to competing.

Each competitor shall wear the colored lycra vest as stated in rule 9.1.4. Competitors not wearing the colored lycra vest or not wearing it correctly during their heats will not be scored and may be penalized as specified under rule 11.2 fine schedules.

After the competitor has completed her heat, the colored lycra vest shall be returned to the Beach Marshall when returning to the beach. Competitors failing to return their colored lycra vest after their heat may be penalized as specified under rule 11.2 fine schedules.

20.1.2 Under rule 11.2 fine schedules, a competitor failing to show at his heat to compete without prior notification to the Contest Director may be penalized.

20.1.3 When a competitor does not show at his heat, the competitor(s) must compete the heat alone(s) in case the opponent turns up late. Only if the Contest Director is informed and confident that the competitor will not be competing in their scheduled heat, the daily schedule can be adjusted to reduce the event's running time.

20.1.4 Competition area:

(i) The competition area shall be defined in the Official Notice Board at least fifteen (15) minutes before the start of the heat.

(ii) Each competitor shall be inside the designated competition area to be scored. Head Judge will be who decide if a competitor is in or out of the competition area.

(iii) A competitor shall not kite in the competition area while competition is going on, other than during her own heat. A competitor infringing this rule may be penalized as specified under rule 11.2 fine schedules.

- (iv) In some occasions offset marks may be used. These marks have to be rounded or passed by the competitors before attempting a trick inside the competition area.

20.1.5. Interferences:

A competitor shall not interfere with another competitor's right-of-way. Interference may be called if:

- (i) a competitor hinders the scoring potential of a competitor deemed to have right of way.
- (ii) there is deliberate unsportsmanlike action by the competitors in the heat.
- (iii) a competitor doesn't make all assumptions necessary about his jump length, duration and direction to avoid contact with other competitors.

20.1.6 Interference penalty:

- (i) Only if the majority of the judges called the interference the Head Judge shall call an interference penalty.
- (ii) To call an interference penalty a black flag together with a colored flag corresponding to the competitor's competition vest colors in the water will be used when possible. The flag color code used will be posted in the Official Notice Board.
- (iii) If an interference penalty is called on a competitor, then the competitor's final score will be penalized with a loss of 50% of his best scoring trick.
If a Competitor incurs a second interference penalty during the heat, he must immediately leave the competition area and won't be scored from that point, losing 100% of his best scoring trick.

20.1.7 Outside assistance:

Each competitor's efforts on the water shall be individual with only the following means of outside assistance being allowed:

- (i) Competitors that during their heat end up downwind of the competition area will be allowed to make their way back to the competition area by walking upwind on the beach by themselves or getting assistance of another competitor.
- (ii) During the heat, a competitor could get assistance to re-launch his kite inside of the competition area only from a competitor

competing in his heat. A competitor could get assistance to re-launch his kite only when the downed kite is out of the competition area.

- (iii) If a competitor gets assistance inside the competition area from the rescue boat, press boat, Jet ski, or any other craft, they will be disqualified from that heat. The Contest Director can make changes to this rule at certain events.
- (iv) If a competitor loses his kite during the heat from equipment failure, he will be allowed to replace his kite only outside from the competition area. The competitor has to get out from the competition area by his own means. If he is not wearing a leash, he will not be scored from the point he loses his kite.

Any non permitted outside assistance in the heat shall be penalized by a warning or disqualification if in the opinion of the Head Judge or Contest Director, such assistance materially prejudiced the result.

20.2 Signals and heat duration

20.2.1 Signals.

(i) Starting Signals:

Warning: Red flag displayed.

Preparatory: Red flag removed, yellow flag up

Starting: Yellow flag removed, green flag displayed.

- (ii) Each visual signal may be accompanied by a sound signal, but times shall be taken from the visual signals and mistiming or failure of a sound signal shall be disregarded.

20.2.2 Heat duration.

The heat duration shall be from 5 up to 30 minutes. The transition intervals shall be posted on the Official Notice Board.

20.3 Postponing and abandoning a heat

20.3.1 The Contest Director may

- (i) postpone or abandon a heat for any reason before the starting signal.
- (ii) after the starting signal abandon a heat because of insufficient wind, or foul weather, or an error in the starting procedure, or because a mark is missing, for other reasons directly affecting the fairness of competition. The time limit for such abandonment shall be two minutes before the end of the heat.

(iii) Postpone or abandon a heat at any time for safety reasons.

20.3.2 Postponement:

A postponement shall be signaled by the raising of the “Answering Pendant”, accompanied by two (2) sound signals. After a postponement the ordinary starting signals shall be used according to rule 20.2.1. The postponement signal shall be lowered, accompanied by a sound signal, one minute before the first warning signal is made.

20.3.3 Abandonment:

The raising of code flag “N”, accompanied by three (3) sound signals, shall signal that the present heat is abandoned.

21 RIGHT OF WAY RULES

21.1 General Right of way rules

The choice of right-of-way criteria for each of the above possible situations is the responsibility of the KWT Head Judge, race director or the senior available touring KWT Judge in that order.

21.1.1 A competitor has the right of way over another competitor when the other competitor is required to keep clear of them. However, some rules limit the actions of a right- of- way competitor.

21.1.2 On opposite tacks

When competitors are on opposite *tacks*, a *port-tack* competitor shall *keep clear* of a *starboard-tack* competitor.

(i) When two competitors on opposite *tacks* cross each other, the *windward* competitor shall keep their kite high while a *leeward* competitor shall keep their kite down to avoid a *tangle*.

(ii) When two competitors are on opposite *tacks* and equally upwind, the *starboard-tack* competitor shall cross-upwind keeping the kite high while the *port-tack* competitor shall cross-downwind, keeping the kite low.

21.1.3 On the same tack, overlapped

When competitor are on the same *tack* and *overlapped*, a *windward* competitor shall *keep clear* of a *leeward* competitor.

21.1.4 On the same tack, not overlapped

When competitors are on the same *tack* and not *overlapped*, a competitor *clear astern* shall *keep clear* of a competitor *clear ahead*.

21.1.5 When a competitor changes *tack*, gaining upwind position, they shall *keep clear* of other competitors until they are moving on an upwind course. During that time rules 21.1.4, 21.1.5 and 21.1.6 do not apply.

If two competitors are subject to this rule at the same time, the one on the other's port side or the one astern shall keep clear.

21.1.6 A competitor making a *transition* shall *keep clear* of a competitor on a tack.

21.1.7 If two competitors converge while sailing downwind and it is not possible under rules 21.1.4, 21.1.5 and 21.1.6 to determine which one has right of way:

(i) if they are *overlapped*, the one on the other's starboard side shall *keep clear*.

(ii) if they are not *overlapped*, the one *clear astern* shall *keep clear*.

21.1.8 When sailing downwind, if one competitor is *looping their* kite and another is not, the competitor that is *looping their* kite shall keep clear of the one that is not.

21.1.9 Avoiding contact

A competitor shall avoid contact with another competitor if reasonably possible. However, a right-of-way competitor or one entitled to *room* or *mark-room*:

(i) need not act to avoid contact until it is clear that the other competitor is not keeping clear or giving room or mark-room,

(ii) shall be exonerated if they break this rule and the contact does not cause damage or injury.

21.1.10 Acquiring right of way

When a competitor acquires right of way, they shall initially give the other competitor *room* to *keep clear*, unless they acquire right of way because of the other competitor's actions.

21.1.11 Changing course or kite position

When a competitor with right-of-way changes course or the position of their kite, they shall give the other competitor *room to keep clear*.

21.1.12 A *windward* competitor shall not *jump* when a *leeward* competitor is in close proximity.

21.1.13 A jumping competitor shall *keep clear* of competitor that is not.

21.1.14 Competitors shall not change course to obstruct another competitor (blocking).

21.1.15 Competitors shall stay clear of the competition area when not competing.

21.1.16 Competitors shall not land jumps on the beach, and shall stay clear of any natural obstructions near the competition area.

21.1.17 If possible, a competitor shall avoid a competitor who has crashed or whose kite is in the water, or who is trying to help a person or vessel in danger.

21.1.18 A competitor who has crashed or run aground shall not interfere with another competitor.

21.1.19 During a *tangle* or collision, if an affected competitor is not competing against the competitor at fault and the action penalizes the competitor's performance, limiting his chances of winning the heat, the affected competitor's heat may be re-run.

21.1.20 From the warning signal to the starting signal, a competitor returning to the shore after competing has to *keep clear* of a competitor who is entering the competition area to compete.

21.1.21 If reasonably possible, a competitor that is not *competing* shall not interfere with a competitor that is *competing*.

21.1.22 In the case of a deliberately unsportsmanlike action by the competitors in the heat, dangerous action, *tangle* or collision, as a result of the infringement of any of the above rules, a warning or disqualification from the heat could be awarded at the discretion of the Contest Director or Head Judge.

22 JUDGING

22.1 Judging Procedure

22.1.1 Selection of judges

Only the KWT Sports Commission can make appointments and substitutions for an event.

22.1.2 One or two panels of judges, each panel comprising an odd number of judges, no less than three (3) in number, shall score each heat. The scores of the respective competitors will be tabulated together to get their results from the heat.

(i) The judges shall award each competitor's tricks points on a scale from 1 to 10 in the corresponding scoring trick category to be scored in increments of 1/10th of a point.

(ii) Scores are awarded in a number of categories. The number of scoring categories to be counted towards the final result and the multiplication factor for each category are described in rule 22.2.2. Depending on the given conditions, weight given to each scoring category shall be modified and will be announced by the Head Judge and posted in the Official Notice Board at least thirty (30) minutes before the start of the heat.

(iii) Judges have to tabulate their scores to determine the final score per trick

(iv) When there are five (5) judges, the highest and the lowest scores per heat will be withdrawn and the average scores of the other three (3) judges will be counted as the final trick score after applying the corresponding multiplying factor.

(v) The scores of the respective competitors shall be tabulated together to determine the winner: highest points wins.

(vi) A flag out system may be used to eliminate the competitor with the lowest scores and continue the heat keeping the current heat scores from the remaining competitors on the heat. In case of tie, it will be broken in favour of the competitor with the highest single score. If a tie remains between two or more competitors, each competitor's individual scores shall be listed in order of best to worst, even if some of them are excluded scores, and at the first point where there is a difference the tie shall be broken in favor of the competitor with the best individual score.

(vii) All the judges shall write their full names or identifiable abbreviations on the judging sheets.

(viii) The Head Judge will be able to understand the shorthand notes of the individual judges and will be able to explain judgment to the riders.

(ix) The judging scores of each individual judge shall be shown only to competitors in that heat, on their request.

(x) Competitors are not allowed to stay in the judge's tower. If a competitor wants to check his judging scores, he shall ask for consent from the Head Judge to enter the judge's tower.

(xi) The scores and the decisions of the judges shall not be appealed.

22.1.3 The Head Judge must be sure that the judges do not discuss scores.

22.1.4 Re-running of heats

The Head Judge has the power to re-run a heat if there is strong evidence that there is a major discrepancy in the judging scores from each individual judge.

If it is possible, the decision to re-run heats shall be made before announcing a winner of the heat in question.

22.2 Scoring

22.2.1 There is no limitation in maximum number of trick attempts per heat or repetition of the same tricks.

22.2.2 Only the 3 best tricks with the highest individual scores and from different trick categories will count towards the final score.

22.2.3 If a competitor "butt checks" when landing the trick and doesn't lose the board, the judges will still give some credit to the trick. It's at the discretion of each judge to consider if it's a crash or a butt check and to consider how much credit they will give to the trick.

22.2.4 The credit given to butt checked trick landings is directly related to the risk factor involved in the execution of the trick. For tricks with a high degree of risk factor, judges won't deduct points for a butt-checked landing.

- 22.2.5 A trick is a crash only if the majority of the judges consider it as a crash. If the minority of the judges consider a trick as a crash, those crashes will be withdrawn and the judges will reconsider the trick in the other scoring categories.
- 22.2.6 If a judge misses a trick, he should place a “M” and he has to consult to the Head Judge before giving the final score of the heat.
- 22.2.7 The Head Judge may re-run the heat according to rule 22.1.4, if all judges miss a trick and there is strong evidence that the trick was missed by all the judges and this trick may change the final result.
- 22.2.8 Judges may not change their scores. If there are any mistake the judge should have the Head Judge make the correction for them.
- 22.2.9 Tied competitors’ heat scores shall be listed in order of best to worst individual scores and at the first point where there is a difference the tie shall be broken in favor of the competitor with the best individual score.

22.3 Trick categories:

22.3.1 The tricks repertoire has been broken up into the following tricks categories. The list of tricks included by category is not extensive, and not limited to the described tricks below but gives an indication about how different tricks are being categorized by the judges. The Head Judge has the final say when categorizing a new trick.

REGULAR JUMP		BOARD OFF		KITELOOP		HANDLE PASS	
BACK ROLL	BR	ONE FOOT	OF	KITELOOP	KL	KUNG FU PASS	KFP
2X BACK ROLL	2BR	BOARD OFF	BO	KITELOOP LATE BACK	KL B	KUNG FU 2 PASS	KF2P
3X BACK ROLL	3BR	TIC TAC	TT	BOOGIE LOOP	BL	DANGLE PASS	DP
FRONT ROLL	FR	FLIP	F	KITELOOP 2X HALF CAB	KL2HC	2X DANGLE PASS	2DP
DOUBLE FRONT ROLL	2FR	BOARD PASS	BP	KITELOOP KGB	KLKGB	3X DANGLE PASS	3DP
TRIPLE FRONT ROLL	3FR	KITELOOP ONE FOOT	KLOF	KITELOOP 360 HP	KL3	MOBE	MOBE
DEAD MAN	DM	KITELOOP BOARD OFF	KLBO	KITELOOP 540 HP	KL5	HEART ATTACK	HA
KUNG FU	KF	KITELOOP FRONT BOARD OFF	KLFRBO			HEART ATTACK 7	HA7

22.3.2 Each above trick category are mandatory in order to bring the variety criteria into effect. Only the highest or two highest score per trick category will count towards the final heat score from each competitor.

22.3.3 Two different trick categories could be combined depending on the wind conditions and will be announced by the Head Judge and

posted in the Official Notice Board at least thirty (30) minutes before the start of the heat.

22.4 Judging Criterias and scoring categories:

22.4.1 Judges will assign numerical values to each trick attempt based on the following judging criterias:

(i) Height and amplitude – The combination of height and amplitude of the tricks completed during the heat. As the wind conditions increase, this aspect will exponentially become more and more into consideration, but only when the height and amplitude are achieved along with risk factor and technical difficulty.

(ii) Technical Difficulty – The technical difficulty of tricks completed during the heat. A grabbed trick will be rewarded with a higher score than a non-grabbed trick within this criteria, depending on the quality of the execution.

(iii) Power – The power during the execution of the tricks. Power will be considered as a combination of speed in and out of the trick to pop, height and amplitude of the trick.

(iv) Risk factor – Is directly linked to the power, height, amplitude and technical difficulty of the jump, but also to the commitment of the competitor and physical challenge during the execution, duration of the critical moment, and energy on the execution.

(v) Smoothness – Smoothness and fluidity during the execution and landing of tricks completed during the heat.

(vi) Innovation – Tricks that have never been landed in competition before.

22.4.2 These judging criteria's are weighted into the following two (2) main scoring categories:

(i) Air – It represents 50% of the score per trick and is a combination of height, amplitude, power, risk and “wow” factor of the tricks.

(ii) Technical Difficulty – It represents 50% of the score per trick and it's the technical difficulty of tricks completed during the heat.

Weight given to each scoring category may be modified depending on the wind conditions and will be announced by the Head Judge and posted in the Official Notice Board at least thirty (30) minutes before the start of the heat.

22.5 Other judging aspects

22.5.1 A crash will be considered when:

- (i) when landing a trick, a competitor is *capsized*, losing control of the board or bar.
- (ii) a competitor finishes a handlepass by pulling the leash to get the bar.
- (iii) a competitor lands a jump but loses the bar.
- (iv) a competitor lands a jump but crashes the kite into water and completely stops.
- (v) a competitor is completely stopped when landing a jump.
- (vi) a competitor lands on their back and lose the control of the board.

22.5.2 Judges may give credit to a landed trick that is not a crash when:

- (i). a competitor butt-checks when landing the trick but keeps riding and control the kite.
- (ii). a competitor grabs the “chicken loop” to regain control of the bar.
- (iii). a competitor lands a jump and crashes the kite into the water, but manages to relaunch it and keep riding without completely stopping.

23 INTELLECTUAL PROPERTY RIGHTS

23.1 All rights at the *GKA Kiteboarding World Tour Rulebook* are reserved by the Global Kitesports Association e.V. (GKA).